

13

EXULANS
TAPING TOOLS
By **COLOTOOL**

Encintado automático y semiautomático

Ferramentas para gesso laminado / Jointoement / Taping tools

Encintadora automática

Aplicador automático de fita e massa. / Applicateur automatique. / Automatic taper.



REF.	EAN	€ P.V.P.
29000	8 435469 803237	1300 1.328,00



EXULANS
TAPING TOOLS
By **COLOTOOL**

- Aplica la cinta y la pasta de juntas en un sólo proceso. • Aplica a fita e a pasta num único processo.
- Appliquer la bande et la pâte à joint en une seule fois. • Apply the tape and the joint compound in a single process.

Bomba de carga (boquilla incluida)

Bomba de carregamento (bocal incluído). / Pompe de charge (buse incluse). / Compound pump (filler included).

REF.	EAN	€ P.V.P.
29006	8 435469 803244	391,65



EXULANS
TAPING TOOLS
By **COLOTOOL**

- Impulsa la pasta desde el recipiente donde se aloja hasta los componentes de encintado automático.
- Conduz a massa do contentor para os componentes de ferramentas automaticas.
- Transporte la pâte depuis le conteneur jusqu'aux composants automatiques de l'outil.
- Drives the joint compound from the container where it stays until the components of automatic taping.

Cuello de cisne / Pescoço de cisne. / Le col de cygne. / Gooseneck.

REF.	EAN	€ P.V.P.
29008	8 435469 803251	89,75



EXULANS
TAPING TOOLS
By **COLOTOOL**

- Carga la encintadora automática • Carrega o aplicador automático.
- Indiqué pour remplir l'applicateur automatique. • Loads the automatic taper.

Boquilla de carga / Bocal de carregamento. / Buse de remplissage. / Filler.

REF.	EAN	€ P.V.P.
29007	8 435469 803268	44,85



EXULANS
TAPING TOOLS
By **COLOTOOL**

- Carga las cajas planas, los alimentadores de rincón y las cajas tapatornillos
- Para encher caixas de acabamento, alimentador de canto e caixa tapa parafusos.
- Pour remplir les boîtes de vis et les boîtes de finition.
- Loads the flat boxes, corner applicators and nail spotters.

Caja plana para acabados / Caixa de acabamento plana. / Boîte de finition. / Flat box.

v2

- Nuevo sistema de bisagra para facilitar deslizamiento, apertura y limpieza.
- Novo sistema de dobradiças para facilitar o deslizamento, a abertura e a limpeza.
- Nouveau système de charnières pour faciliter le glissement, l'ouverture et le nettoyage.
- New hinge system for easy sliding, opening and cleaning.
- Cierres ABS más rápidos. • Nueva fijación de muelles.
- Fixações ABS mais rápidas. • Nova fixação da mola.
- Attaches ABS plus rapides. • Nouvelle fixation du ressort.
- Faster ABS fasteners. • New spring fixation.

REF.	EAN	€ P.V.P.
29010	8 435469 803275	203 8" 313,00
29011	8 435469 803282	254 10" 321,00
29012	8 435469 803299	305 12" 332,00
29013	8 435469 809802	355 14" 345,00

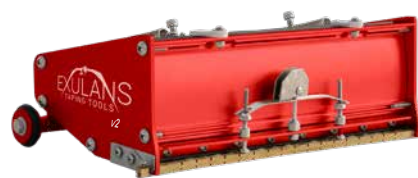

VERSIÓN MEJORADA
NEW VERSION

+ Robusta
Mejores acabados

MAXI

- Distribuye la pasta uniforme y remata las juntas gracias a la cuchilla incorporada, ya sean horizontales o verticales.
- Espalha a massa uniformemente e remata as juntas com a lâmina incorporada, tanto na horizontal como na vertical.
- Il étale la pâte de façon homogène et termine les joints avec la lame intégrée, qu'ils soient horizontaux ou verticaux.
- Applies joint compound evenly and finishes either horizontal or vertical joints thanks to the incorporated blade.

EXULANS
TAPING TOOLS
By **COLOTOOL**

Mango para cajas planas *Cabo para caixas planas. / Manche pour boîtes de finition. / Flat box handle.*

REF.	EAN	€ P.V.P.
29015	8 435469 803305	1066,8 144,00
29016	8 435469 803312	1371,6 157,00

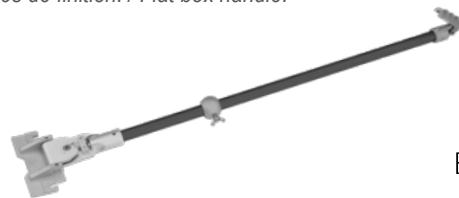

Mango extensible PRO para cajas planas reforzado

Cabo extensível PRO de caixa plana. / Manche extensible PRO pour boîte plate. / PRO extendable flat box handle.

REF.	EAN	€ P.V.P.
29019	8 435469 809819	1040-1605 317,00



• Ø 35 mm. Más robusto. • Ø 35 mm. Mais robusto. • Ø 35 mm. Plus robuste. • Ø 35 mm. More robust.

Rodillo de rincón *Rolo de canto interior. / Rouleau d'angle rentrant. / Inside corner roller.*

REF.	EAN	€ P.V.P.
29045	8 435469 803428	- 110,00



• Una vez aplicada la cinta en rincones, se utilizará para presionar la cinta sobre la superficie y expulsar el exceso de pasta.
• Quando a fita tiver sido aplicada nos cantos, será utilizada para pressionar a fita sobre a superfície e espremer o excesso de pasta.

• Une fois que le ruban a été appliqué dans les coins, il sera utilisé pour presser le ruban sur la surface et pour presser l'excès de pâte.
• Once the tape has been applied to the corners, it will be used to press the tape onto the surface and squeeze out the excess paste.

Rodillo de esquinas

Rolo de esquinas / Rouleau d'angle sortant / Outside corner roller.

REF.	EAN	€ P.V.P.
29048	8 435469 803435	- 81,60



• Una vez colocados los guardavivos en las esquinas se utilizará para presionarlos y expulsar el exceso de pasta.
• Quando as protecções dos cantos tiverem sido colocadas nos cantos exteriores, este rolo será utilizado para as pressionar e forçar o composto a sair.

• Une fois que les cornières ont été placées sur les angles extérieurs, ce rouleau sera utilisé pour les presser et faire sortir la pâte à modeler.
• Once the corner guards have been placed on the outside corners, this roller will be used to press them and force the compound out.

Mango para rodillos / caja tapatornillos

Cabo de rolos - caixa de parafusos. / Manche à rouleau - boîte de vis. / Roller handle and screw cover box.

REF.	EAN	€ P.V.P.
29057	8 435469 803459	1270 87,00



Mango universal extensible

Cabo extensível universal. / Manche extensible universel. / Universal extendable handle.

REF.	EAN	€ P.V.P.
29070	8 435469 803466	965-1575 130,00



Adaptador para rodillos - caja tapatornillos

Adaptador de rolos - caixa de parafusos. / Adaptateur de rouleau - boîte à vis. / Roller adapter - screw cover box.

REF.	EAN	€ P.V.P.
29055	8 435469 803442	- 16,30



Terminador de rincón *Terminador de canto. / Tête d'angle. / Corner finisher.*

REF.	EAN		€ P.V.P.
29030	8 435469 803374	 63,5 2,5"	373,00
29032	8 435469 803381	88,9 3,5"	386,00



- Tras utilizar el rodillo de rincón, remata los rincones donde se ha aplicado la cinta.
- Depois de utilizar o rolo de canto, terminar os cantos onde a fita foi aplicada.
- Après avoir utilisé le rouleau d'angle, terminez les angles où le ruban a été appliqué.
- After using the corner roller, finish off the corners where the tape has been applied.

Mango para terminador - repasador de rincón

Cabo de terminador - alisador de ângulo. / Manche de terminaison - lisseurs d'angle. / Finishers and corner flusher handle

REF.	EAN		€ P.V.P.
29037	8 435469 803404	 1270	86,70

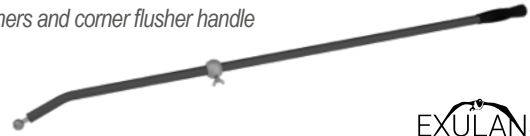

Mango universal extensible

Cabo extensível universal. / Manche extensible universel. / Universal extendable handle.

REF.	EAN		€ P.V.P.
29070	8 435469 803466	 965-1575	130,00



Adaptador terminador - repasador de rincón

Adaptador de terminador - alisador de ângulo. / Adaptateur de terminaison - lisseurs d'angle. / Finishers and corner flusher adaptor.

REF.	EAN		€ P.V.P.
29035	8 435469 803398	 -	24,50



Alimentador de rincón

Alimentador de canto. / Boîte d'angle. / Corner applicator.

REF.	EAN		€ P.V.P.
29020	8 435469 803343	 203,2 8"	254,00



- Junto a terminadores de rincón, se utilizará para cargar pasta y rematar el rincón cuando sea necesario.
- Juntamente com rematadores de cantos, será utilizado para carregar pasta e rematar o canto quando necessário.
- Avec les finisseurs d'angle, il sera utilisé pour charger la pâte et finir l'angle si nécessaire.
- Together with corner finishers, will be used to load joint compound & finish the corner angle whenever necessary.

Mango para alimentador de rincón

Cabo angular de alimentador de canto. / Manche boîte d'angle. / Corner applicator handle.

REF.	EAN		€ P.V.P.
29027	8 435469 803367	 1270	83,65



Mango universal extensible

Cabo extensível universal. / Manche extensible universel. / Universal extendable handle.

REF.	EAN		€ P.V.P.
29070	8 435469 803466	 965-1575	130,00



Adaptador alimentador de rincón

Adaptador para alimentador de canto. / Adaptateur boîte d'angle. / Corner applicator adaptor.

REF.	EAN		€ P.V.P.
29025	8 435469 803350	 -	24,50



Caja tapatornillos *Caixa tapa parafusos. / Boîte de vis. / Nail spotter.*

REF.	EAN		€ P.V.P.
29040	8 435469 803411	 76 3"	210,00



• Aplica pasta sobre los tornillos de manera fácil y rápida, dejando completamente terminada la superficie. Puede ser utilizada tanto en paredes como en techos.

• Aplica a pasta sobre os parafusos de forma rápida e fácil, deixando a superfície completamente acabada. Pode ser utilizado tanto em paredes como em tectos.

• Il applique la pâte sur les vis rapidement et facilement, laissant la surface complètement finie. Peut être utilisé sur les murs et les plafonds.

• It applies paste over the screws quickly and easily, leaving the surface completely finished. It can be used both on walls and ceilings.

Mango para rodillos / caja tapatornillos

Cabo de rolos - caixa de parafusos. / Manche à rouleau - boîte de vis. / Roller handle and screw cover box.

REF.	EAN		€ P.V.P.
29057	8 435469 803459	 1270	87,00



Mango universal extensible

Cabo extensível universal. / Manche extensible universel. / Universal extendable handle.

REF.	EAN		€ P.V.P.
29070	8 435469 803466	 965-1575	130,00



Adaptador para rodillos - caja tapatornillos

Adaptador de rolos - caixa de parafusos. / Adaptateur de rouleau - boîte à vis. / Roller adapter - screw cover box.

REF.	EAN		€ P.V.P.
29055	8 435469 803442	 -	16,30



HERRAMIENTAS DE ENCINTADO SEMIAUTOMÁTICO

FERRAMENTAS SEMI-AUTOMÁTICAS / JOINTOIEMENT SEMI-AUTOMATIQUE / SEMI-AUTOMATIC TAPING TOOL

Aplicador de pasta Aplicador de massa. / Tube d'enduit (Seringue). / Joint compound applicator.

REF.	EAN	€ P.V.P.
29084	8 435469 803497	609,6 179,00
29086	8 435469 803503	914,4 211,00
29087	8 435469 806849	1143 250,00



EXULANS
TAPING TOOLS
by COLOTOOL

- Aplica pasta de juntas a través de los terminadores de rincón y los cabezales.
- Aplicá-la usando os terminadores de canto e cabeças aplicadoras de massa.
- Pour l'application à l'aide des terminaisons d'angle et des têtes.
- For application using the corner terminators and heads.

Cabezales planos para aplicador de pasta (con ruedas o patines)

Cabeça aplicadora plana (c/rodas c/patins). Tête d'application plate (avec roues o patins) / Flat applicator head (w/wheels or skids)

REF.	EAN	€ P.V.P.
29088	8 436534 151628	120x62 95,00
29089	8 435469 803527	120x62 88,00



EXULANS
TAPING TOOLS
by COLOTOOL

- Fabricados en aluminio anodizado. • Fabricado em alumínio anodizado. • Fabriqué en aluminium anodisé. • Made of anodised aluminium.

Cabezales para aplicador de pasta (rincones o esquinas)

Cabeças aplicadoras pasta (cantos e fendas). Têtes d'application de pâte (coins et recoins) / Paste applicator heads (nooks or corners)

REF.	EAN	€ P.V.P.
29090	8 435469 803534	75x100x55 77,50
29095	8 435469 803541	85x100x65 77,50

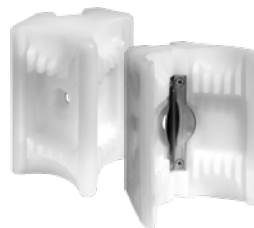

EXULANS
TAPING TOOLS
by COLOTOOL

- Fabricado en PVC. • Fabricado em PVC. • Fabriqué en PVC. • Made of PVC.

Repasador de rincón Alisador de angulo. / Lisseurs d'angle. / Corner flusher

REF.	EAN	€ P.V.P.
29060	8 435469 803473	63,5 2,5" 121,00
29061	8 435469 803480	89 3,5" 142,00



EXULANS
TAPING TOOLS
by COLOTOOL

- Repasa y deja perfectamente terminados los rincones. • Refinir et laisser les coins parfaitement finis.
- Revestir e deixar os cantos perfeitamente acabados. • Refinish and leave the corners perfectly finished.

Mango para alimentador de rincón

Cabo angular de alimentador de canto. / Manche boîte d'angle. / Corner applicator handle.

REF.	EAN	€ P.V.P.
29027	8 435469 803367	1270 83,65



EXULANS
TAPING TOOLS
by COLOTOOL

Mango universal extensible

Cabo extensível universal. / Manche extensible universel. / Universal extendable handle.

REF.	EAN	€ P.V.P.
29070	8 435469 803466	965-1575 130,00



EXULANS
TAPING TOOLS
by COLOTOOL

Adaptador terminador - repasador de rincón

Adaptador de terminador - alisador de ângulo. / Adaptateur de terminaison - lisseurs d'angle. / Finishers and corner flusher adaptor.

REF.	EAN	€ P.V.P.
29035	8 435469 803398	- 24,50



EXULANS
TAPING TOOLS
by COLOTOOL

EQUIPOS COMPLETOS EXULANS
EQUIPA COMPLETA / EQUIPE COMPLÈTE / COMPLETE SET

Equipo Completo "A"

Equipa "A" completa. / Équipe "A" complète. / Complete "A" Set.

REF.	€ P.V.P.
29100	4.125,00

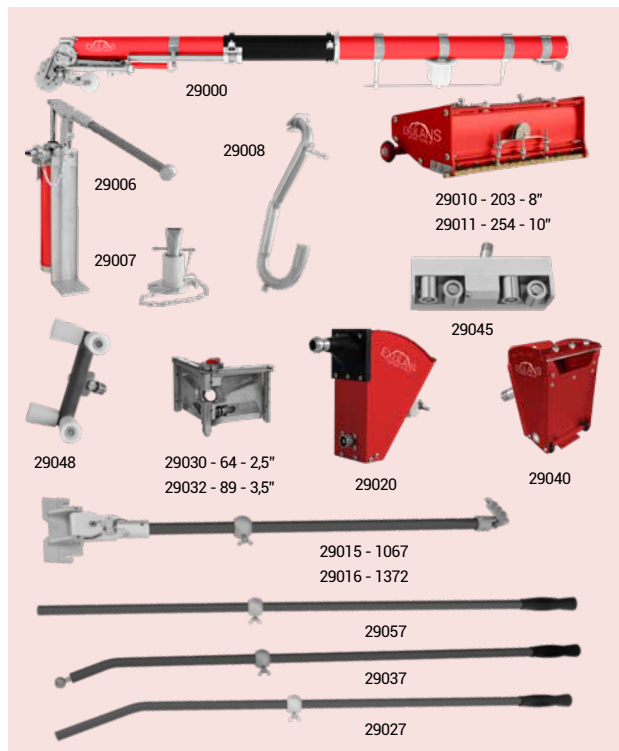

• Es aconsejable adquirir 2 bombas de carga para situaciones de trabajo de encintado y acabado simultáneas.

• É aconselhável adquirir 2 bombas de carga para o trabalho o acabamento simultâneos.

Equipo Completo "B"

Equipa "B" completa. / Équipe "B" complète. / Complete "B" Set.

REF.	€ P.V.P.
29101	4.175,00

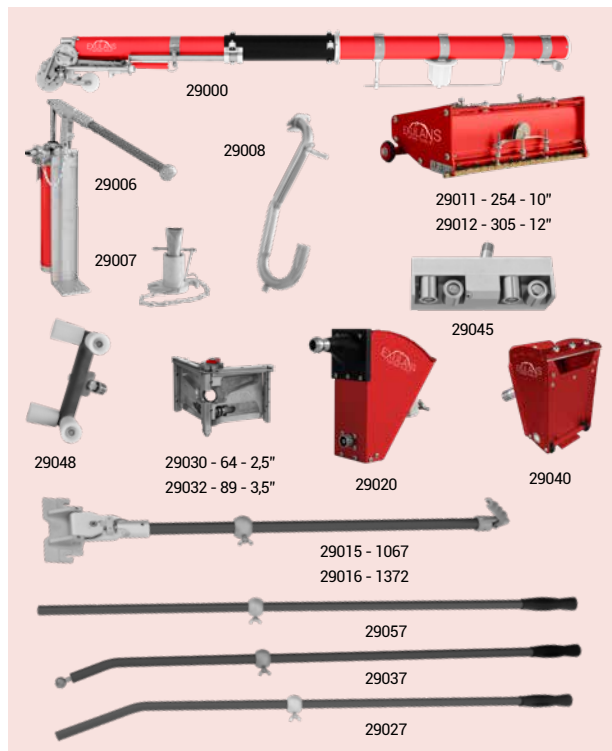

• Il est conseillé d'acheter 2 pompes de charge pour l'emballage et la finition simultanés en même temps.

• It is advisable to purchase 2 charge pumps for simultaneous wrapping and finishing works at the same time.

Equipo de acabado "A"

Equipa acabamento "A". / Équipe "A" finition "A" / Finishing "A" Set.

REF.	€ P.V.P.
29105	2.458,00

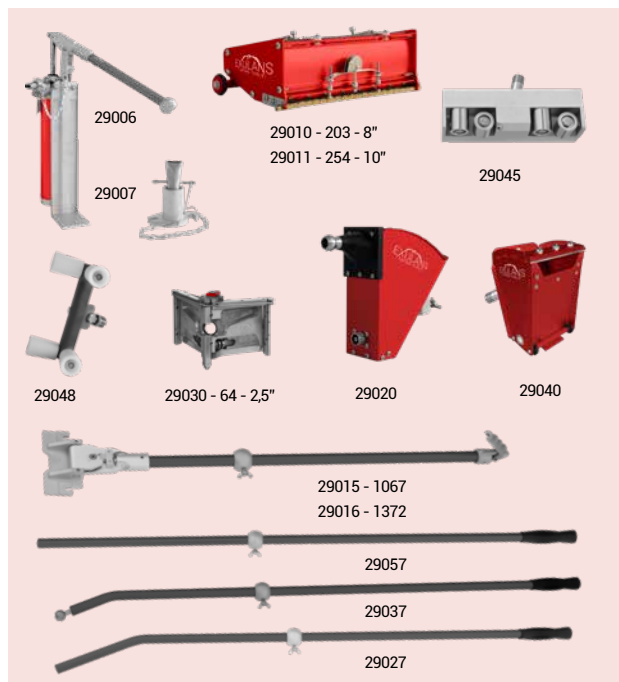

Equipo de acabado "B"

Equipa acabamento "B". / Équipe "B" finition "A" / Finishing "B" Set.

REF.	€ P.V.P.
29106	2.489,00

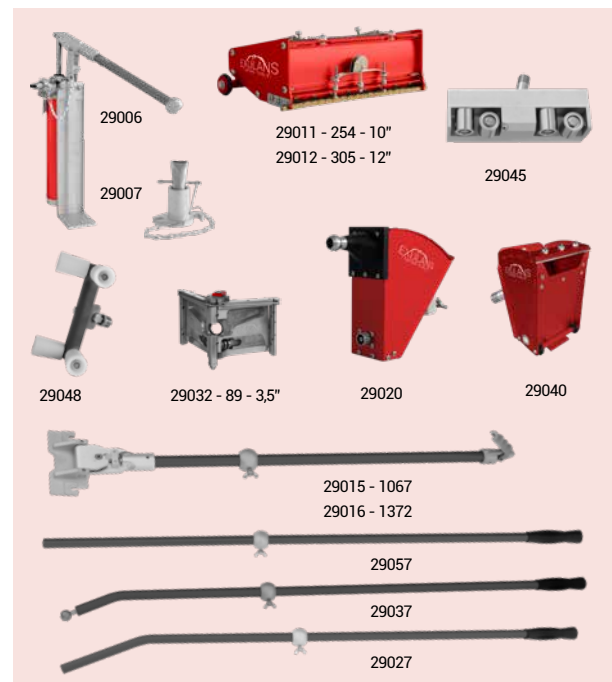

MALETAS ESPECIALES PARA ACABADOS EXULANS

MALAS ESPECIAIS ACABADOS EXULANS / VALISES SPECIALES POUR LA FINITION EXULANS / SPECIAL EXULANS FINISHING CASES

Maleta de acabado nº 1

Mala de acabamento Exulans nº1 / Valise de finition Exulans nº1 / Exulans finishing case nº. 1

REF.	EAN			€ P.V.P.
29111		1305	1	2.412,00



Incluye: / Inclui: / Comprend: / Includes:

29011	Caja plana acabado Caixa de acabamento plana	Boîte de finition Flat Box	254 10"
29012	Caja plana acabado Caixa de acabamento plana	Boîte de finition Flat Box	305 12
29020	Alimentador de rincón Alimentador de canto	Boîte d'angle Corner applicator	203 8"
29030	Terminador de rincón Terminador de canto	Tête d'angle Corner finisher	64 2,5"
29032	Terminador de rincón Terminador de canto	Tête d'angle Corner finisher	89 3,5"
29040	Caja tapatornil Caixa tapa parafusos	Boîte de vis Nail spotter	76 3"
29019	Mango extensible PRO Cabo extensível PRO	Manche extensible PRO PRO Extendable handle	1040-1605
29025	Adaptador alimentador rincón Adaptador alimentador canto	Adaptateur boîte d'angle Corner applicator adaptor	
29035	Adaptador terminador Adaptador terminador	Adaptateur de terminaison Finisher & corner flusher adaptor	
29055	Adaptador para rodillos Adaptador de rolos	Adaptateur de rouleau - boîte à vis Roller adapter - screw cover box	
29070	Mango Extensible Universal Cabo Extensível Universal	Manche Extensible Universal Universal Extendable handle	965-1575
29110	Maleta Exulans 1305 Cabo Extensível Universal	Manche Extensible Universal Universal Extendable handle	1305



- Contenido de la maleta indivisible.
- Conteúdo da mala indivisível.
- Contenu de la valise indivisible.
- The contents of the suitcase are indivisible.

Maleta acabado semiautomático nº 2

Mala de acabamento semi-automática n.º 2 / Valise de finition semi-automatique n.º2 / Semi-automatic finish suitcase no. 2

REF.	EAN			€ P.V.P.
29112		1305	1	1.481,00



Incluye: / Inclui: / Comprend: / Includes:

29087	Aplicador de pasta Aplicador de massa	Tube d'enduit (Seringue) Joint compound applicator	1143
29088	Cabezal plano ruedas Cabeça plana con rodas	Tête plate avec roues Flat applicator head w/wheels	
29090	Cabezal para rincón Cabeça para canto	Tête de pâte pour coin Inside corner applicator head	
29095	Cabezal para esquinas Cabeça ângulo interno	Tête de pâte pour recoins Outside corner applicator head	
29061	Repasador de rincón Alisador de ângulo	Lisseurs d'angle Corner flusher	89 3,5"
29037	Mango fijo terminador rincón Cabo terminador ângulo	Manche de terminaison Finisher handle	1270
29057	Mango de rodillos Cabo de rolos	Manche de terminaison Roller handle	1270
23285	Espátula destornillador plaquista Espátula com chave de fendas	Couteau avec tournevis Scredriver-end putty knife	152
23168	Paletín Rincones Espátula de canto interior	Truelle angle interieur Corner trowel	130 x 100
29045	Rodillo de rincón Rolo de canto interior	Rouleur d'angle rentrant Inside corner roller	
29048	Rodillo de esquinas Rolo de esquinas	Rouleur d'angle sortant Outside corner roller	
29032	Terminador de rincón Terminador de canto	Tête d'angle Corner finisher	89 3,5"
29110	Maleta Exulans 1305 Cabo Extensível Universal	Manche Extensible Universal Universal Extendable handle	1305



- Contenido de la maleta indivisible.
- Conteúdo da mala indivisível.
- Contenu de la valise indivisible.
- The contents of the suitcase are indivisible.

Maleta para encintado nº 3

Mala ferramentas semi-automáticas Exulans nº3 / Valise pour Jointoiment automatique nº3 / Exulans Taping tools suitcase nº 3

REF.	EAN			€ P.V.P.
29113		1305	1	1.852,00



Incluye: / Inclui: / Comprend: / Includes:

29000	Encintadora automática Aplicador automático	Applicateur automatique Automatic taper	1300
29006	Bomba carga * Bomba carregamento*	Pompe de charge * Compound pump *	
29008	Cuello de cisne Pesçoço de cisne	Le col de cygne Gooseneck	203 8"
29110	Maleta Exulans 1305 Cabo Extensível Universal	Manche Extensible Universal Universal Extendable handle	1305



- Contenido de la maleta indivisible.
- Conteúdo da mala indivisível.
- Contenu de la valise indivisible.
- The contents of the suitcase are indivisible.

Maleta EXULANS 1305 Mala EXULANS 1305 / Valise EXULANS 1305 / Suitcase EXULANS 1305

REF.	EAN			€ P.V.P.
29110		1305	1	159,00



• Maleta incompatible con Encintadoras automáticas anteriores a junio de 2023.

• Mala incompatível com aplicador automático anterior a junho de 2023.

• Valise incompatible avec les applicateurs automatiques avant juin 2023.

• Suitcase not compatible with automatic tapers prior to june 2023.

