

L'OUTIL PARFAIT[®]

MANUFACTURER SINCE 1920



EXPORT CATALOGUE

2026



5 PRODUCTION PLANTS

L'Outil Parfait
La Monnerie

HEAD OFFICE
MANUFACTURE OF TOOLS/LOGISTICS SITE

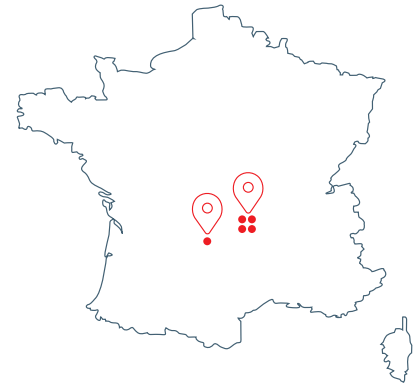

Outiwood
La Monnerie
MANUFACTURE OF
WOODEN HANDLES



Chalimont 1
Brive-la-Gaillarde
MANUFACTURE
OF BRUSHES



Chalimont 2
La Monnerie
MANUFACTURE
OF ROLLERS



Précis Plastic Injection
Orléat
MANUFACTURE OF MOULDS /PLASTIC
INJECTION

55 Million €
in turnover

220 Employees

20 Millions of parts
manufactured

15 000 m² of production
and logistics
space

SOME KEY DATES

1980

New production facilities on a 20,000 m² platform.



1995

Integration of paint roller production (63)



2017

Construction of a new 3,000 m² building with a WMS order scheduling system.



2023

Construction of a new Précis Plastic Injection (PPI) plant.



1920

Creation of the company, then specialized in stationery, straw and painting tools.

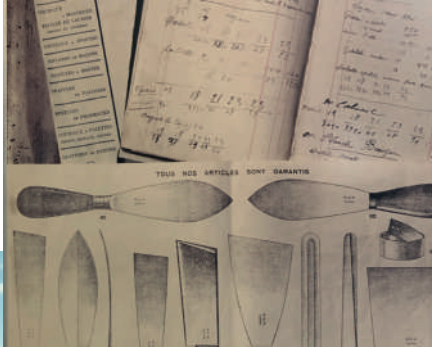

1992

Integration of Chalimont professional brush production in Brive-la-Gaillarde (19).



2013

Précis Plastic Injection (PPI) integration (63).



2020

Expansion of roller production with more than 1,000 m² of storage space.



100 YEARS OF KNOW HOW AND EXPERIENCE IN PRODUCTION

We are proud to present our new range of **ergonomic products for professional use**.

We are elaborating the tools for next generation, **more productive** and made with **recycled raw materials**.

L'Outil Parfait and its salaries is managing a **sustainable orientation** in order to provide a reliable relation with its customers.



Stéphane
Marquardt
CEO



Export team

100% of the products created with our expertise are manufactured in our **factories in France**

5 000 order lines per day

5 000 references in stock

Production,
Quality and
Maintenance
Team

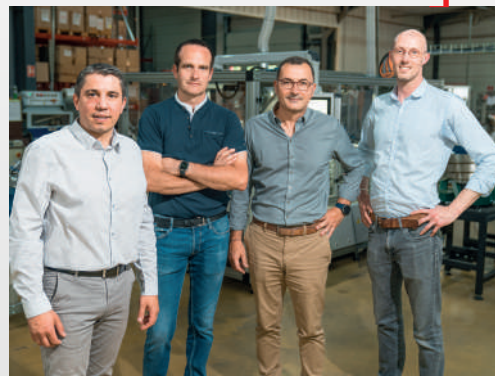

L'Outil Parfait:
*your business
partner for tools*

INNOVATIVE & PATENTED PRODUCTS

HAND TOOLS

[More information on page 26](#)

Traditional and innovative tools for plasterers, painters, floor layers, masons and tilers...

Our design office is the source of numerous patents.

ZOOM ON TRIFLEX®



Lightweight, ergonomic knife with double blade

TEMPERED
STAINLESS
STEEL

TriFlex® technology: the central point of technical support provided by the rigid counter-blade, the straightness of the profile combined with the flexibility of the blade prevents wrist fatigue

ROLLERS

[More information on page 101](#)

ZOOM ON THE TECHNIFIBRE

New weaving technology & hydrophobic fiber treatment: an excellent compromise between resilience, resistance and comfort.



Thermofusion mounting with turned and bevelled edges eliminates paint stripping and burrs at the ends of the roller during application.

Our experience and know-how enable us to develop fabrics in line with the evolution of the paints offered on the professional network.

Multi-paint and multi-surface

BRUSHES

[More information on page 130](#)

Know-how over 75 years old

ZOOM ON THE TECHNIFIL

A range that is constantly evolving to offer **high-performance**, long-lasting synthetic brushes.

New combination of 3 bloom-mounted fibers extensively tested by our design office and by professionals : **precision, retention, restitution**



Our professional brushes are all assembled with PEFC wooden handles.



Lightweight, supple fiber for greater application comfort

Optimized shape retention



PERFECT SOLUTION FOR JOINT TAPING AND FINISHING



THE PROCESS THAT REDUCES MUSCULOSKELETAL DISORDERS (MSDs)

Unlike the traditional method, where the craftsman is often forced to work in uncomfortable positions, straining his back, arms and knees, **L'OP PROCESS'®** offers a more ergonomic solution.

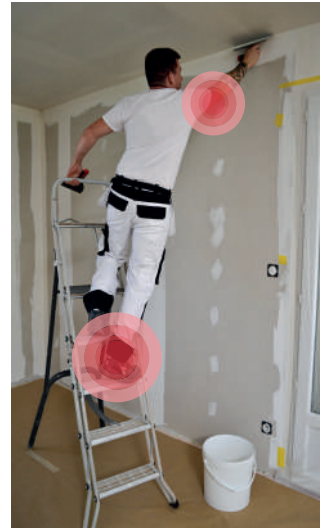

WITH OP PROCESS'®

SAFER AND MORE ERGONOMIC

This method preserves the health of craftsmen while improving the efficiency of their work.

Thanks to pole mounted and light tools and ground-based working methods, the risk of falls is eliminated and muscular fatigue is considerably reduced.



OP PROCESS'® reduces :

- Bad postures
- Twisting movement
- Handling and carrying distance
- The need to lift thing from floor level
- The need to lift thing above the shoulders

OP PROCESS® CONCEPT 9 at 22

The OP PROCESS® concept.....	10 at 13
The Essential Cases of the OP PROCESS®	14 at 20
OP PROCESS® Workstation	21
OP PROCESS® the universal concept.....	22

OP PROCESS® TOOLS..... 23 at 50

Roll'Enduit®	24
RollCut®	25
ParfaitLiss® and kits	28 at 31
Cordless inspection lamp.....	32
OP PROCESS® Workstation	33
Dust free Sanding kit	34 at 36
Plaster joint knives	38 and 39
Flat Box	40 and 41
Delko tools	42
Cutting tools.....	43 at 45
Plasterboard installation accessories	46
E.T.I.C.S.....	47 at 50

HAND TOOLS..... 51 at 86

DécoLiss®.....	52
Faciliss®	53
Joint knives.....	54 and 55
Filling knives	56 at 59
Scrapers.....	60 and 61
Coating knives	62 at 65
Stainless steel trowels.....	66
Finishing trowels	67 and 68
Decorating trowels.....	69 and 70
DecoSol® - Tiling and Flooring	71 at 75
Masonry.....	76 at 86

ROLLERS & BRUSHES..... 87 at 136

Rollers	88 at 107
Eco Paint Rollers	108 and 109
Floor Painting.....	110 and 111
Roller Frames	112 and 113
Extension Poles	114 and 115
Accessories	116 at 120
Brushes	121 at 131
Self-Service Range.....	132 at 136

INDEX 137





The OP PROCESS® concept10

Joint Taping Set 14

RollCut® 15

OP PROCESS® Set 16

Cordless inspection lamp kit 17

ParfaitLiss® Light and Roller Skimming
kit 18

Premium Smoothing kit 19

Dust free Sanding kit 20

OP PROCESS® Workstation21

OP PROCESS® the universal concept ... 22



OP PROCESS®



9 STEPS 5 CASES

1 PERFECT FINISH



WATCH
THE VIDEO



CHECK OUT OUR VIDEOS ON OUR
YOUTUBE CHANNEL
@OUTILPARFAIT1920



JOINT TAPING SET

80624



- 01
- 02
- 04
- 05

ROLLCUT'®

3314000



- 02

CORDLESS INSPECTION LAMP KIT

80401

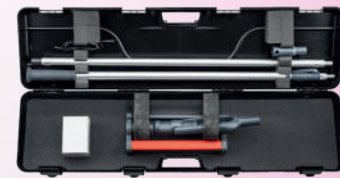

- 06

PARFAITLISS'® LIGHT AND ROLLER SKIMMING KIT

80607



- 07
- 08



DUST FREE SANDING SET

80488



- 09



Thanks to the OP PROCESS'® **Workstation**, the tools follow the craftsman around the job site during every stage of installation. No need to bend down to refill your plaster roller, thanks to the bucket inclination on the **Workstation** and the OP PROCESS'® pole.



OP PROCESS'® OPTIMIZED WITH SCREW-IN POLE

New material:
Improved mechanical strength, guaranteeing lightness and robustness



NEW

1 Single pole = multiple uses

Reduces the number of poles on the work-site for easier tool transport and storage !

The OP PROCESS'® concept allows you to work on the ground thanks to its poles. Its new screw system is more robust.

All our products are developed and manufactured in-house.

Screw thread



Sturdier, self-locking pole

A FAST, EFFICIENT AND ERGONOMIC PROCESS

FASTER

3 times faster than the
traditional process
Skimming up to 25m²/hour
Optimized cleaning and
storage

MORE PROFITABLE

Low investment
Higher productivity
Perfect finishing quality



SAFER AND MORE ERGONOMIC

Lightweight tools
Reduced drudgery and
accidents
Working from the ground

Protect your health with OP Process[®]



STEPS

- 01
- 03
- 04
- 05

Joint Taping Set

NEW



80624

COMPLETE KIT FOR TAPING FLAT AND CORNER JOINTS
Overall compact system.

Includes 2 new products :

Triflex® : double blade knife for embedding and wiping down excess compound

ParfaitLiss® Rigid : stiff blade on second pass (step 5) to avoid any curving inward and get a perfect flat finish.

Case contents

	1 x 7987040	Roll'Enduit® corner 40 mm	
	1 x 987080	Roll'Enduit® 80 mm	
	1 x 987180	Roll'Enduit® 180 mm	
	1 x 1770040	OP Process® Frame 40 mm	p.24
	1 x 1770080	OP Process® Frame 80 mm	
	1 x 1770180	OP Process® Frame 180 mm	
	1 x 763024	TriFlex®	p.26
	1 x 3201000	OP Process® Corner flusher	
	1 x 764035	ParfaitLiss® Rigid 35 cm	p.29
	1 x 1769000	ParfaitLiss® Connector	p.26
	2 x 1766070	OP Process® extension pole 2x0,70 m	p.24



01 APPLYING

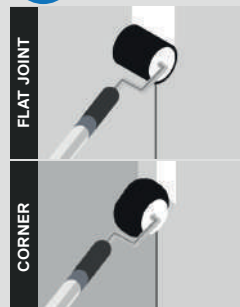

Roll'Enduit® - Divides the time needed to apply coating with a roller by 3 - Use on a pole - Anti-splatter

03 EMBEDDING

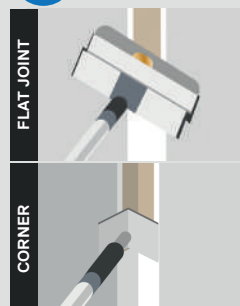

Reinforced pressure due to the double blade + High-performance Bi-Flex technology with PVC counter-blade

04 APPLYING

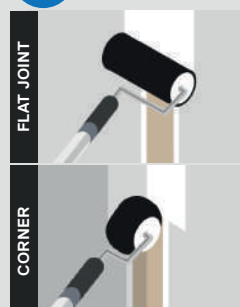

Consistent thickness of the coating, perfectly flat

05 WIPING DOWN

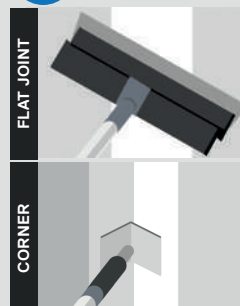

New Soft Comfort non-slip handle

More information on page 27

RollCut®

STEPS

02

OP PROCESS®

FLAT JOINT



Once the compound has been applied, unroll the tape from bottom to top. Embedding with the Triflex®

CORNER



When applying the corner tape from bottom to top, swap the rollers. The tape is automatically shaped to fit the angle. Top tip : the corner trowel is designed to smooth out the tape and facilitate wiping down.

CEILINGS



To apply tape to the ceiling, install the extension of your choice depending on the height and access. Possibility of working at heights of 3 metres.

CEILING EDGES



HARD TO REACH AREAS



The RollCut® without extension fits in a space of 1m (e.g. Cupboards, corridors, toilets, etc.).

OPTIMUM CONNECTION

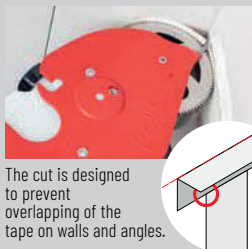

The cut is designed to prevent overlapping of the tape on walls and angles.



3314000

A SINGLE TOOL FOR UNROLLING, MOISTENING, FITTING AND CUTTING PAPER JOINT TAPE

On walls and ceilings, including corners up to 3 m high, without the need for a bench or stilts.

Lightweight design (Net weight: 3.5 kg), Fights against musculoskeletal disorders Easy to clean as it is virtually filler free (safe to clean with water).

The case contains :

- 1 Medium extension for vertical installation
- 1 Long extension for placement in inside corners and at height
- 1 Blade replacement kit

Use the tape moistening to adjust the humidity of the buffer according to the ambient temperature.

GREAT TIP: Soak the strip moistening pad in water for a few minutes before use.

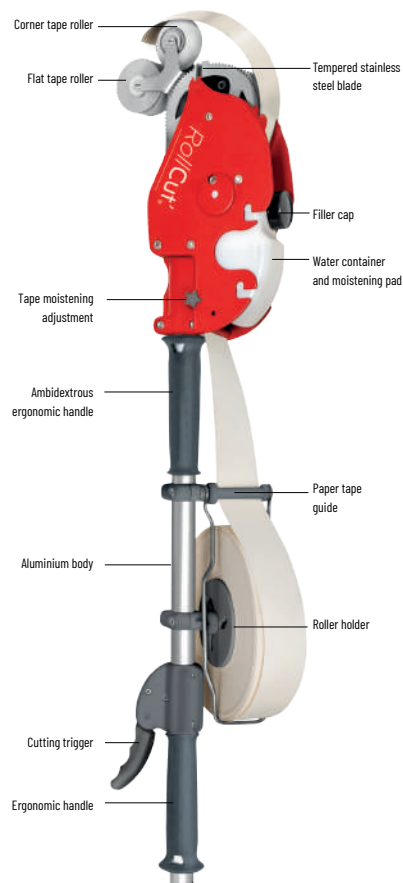

CHECK OUT THE VIDEO

Supplied with 2 extensions

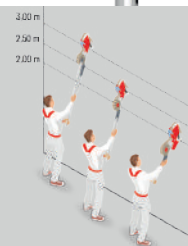

More information on page 25

OP PROCESS'® SET

NEW



80625

15-PIECE KIT FOR FITTING JOINT TAPE New OP Process'® screwable range

Includes 2 new products :

TriFlex'® : double blade knife for embedding and wiping down excess compound.

ParfaitLiss'® Rigid : stiff blade on second pass (step 5) to avoid any curving inward and get a perfect flat finish.

Case contents

	1 x 7987040	Roll'Enduit® corner 40 mm	p.24
	1 x 987080	Roll'Enduit® 80 mm	
	1 x 987180	Roll'Enduit® 180 mm	
	1 x 1770040	OP Process'® Frame 40 mm	p.24
	1 x 1770080	OP Process'® Frame 80 mm	
	1 x 1770180	OP Process'® Frame 180 mm	
	1 x 3201000	OP Process'® Corner trowel	p.26
	1 x 763024	TriFlex'®	
	1 x 764035	ParfaitLiss'® Rigid 35 cm	p.29
	1 x 241045	ParfaitLiss'® Light 45 cm	p.29
	1 x 241060	ParfaitLiss'® Light 60 cm	
	1 x 1769000	ParfaitLiss'® Connector	p.26
	1 x 1766070	OP Process'® extension pole 2x0,70 m	p.24
	2 x 1766100	OP Process'® extension pole 2x1 m	



CHECK
OUT THE
VIDEO



More information on page 27

01 APPLYING

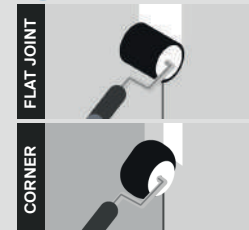

Roll'Enduit® : Divides the time needed to apply coating with a roller by 3 - Use on a pole - Anti-spatter

03 EMBEDDING

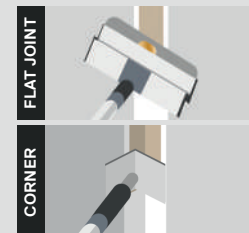

Reinforced pressure due to the double blade + High-performance Bi-Flex technology with PVC counter-blade

04 APPLYING

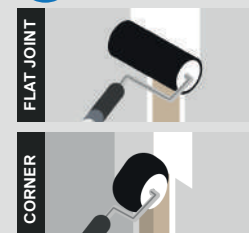

Consistent thickness of the coating, perfectly flat

05 WIPING DOWN

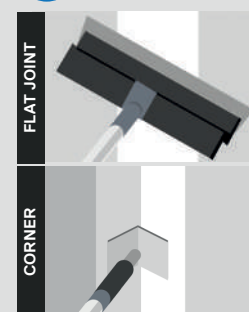

New Soft Comfort non-slip handle

07 APPLYING



The high resilience of the fibre allows the plaster to be held in place without bedding it down and to be evenly distributed across the surface.

08 SMOOTHING



New handle up to 25% lighter - Reusable

STEPS

01

03

04

05

07

08

06 VIEWING



On/off
Button

Rubberised
surface
2 anti-shock
and anti-track
paint tips

3 LEDs
concentrated
beam bulbs,
15° focus

Autonomy
5 hours

Screwable on
telescopic
handle

CORDLESS INSPECTION LAMP KIT

NEW

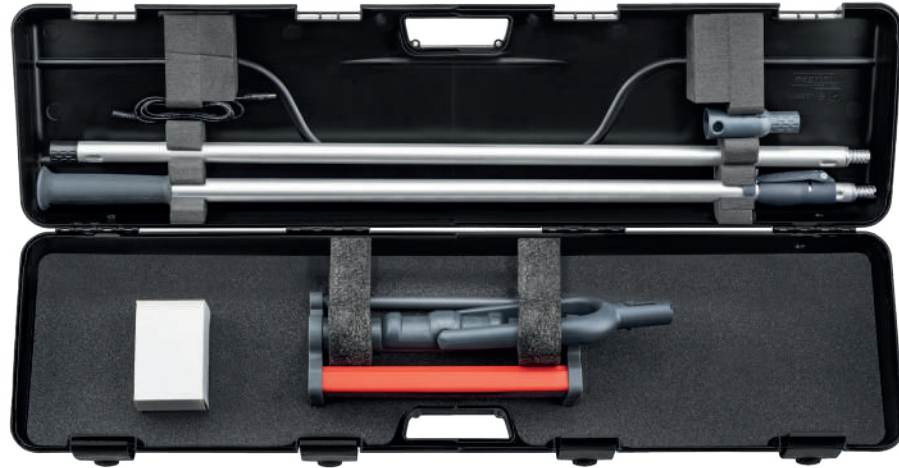

80401

POWERFUL WIRELESS LIGHT FOR REAL-TIME DEFECT DETECTION IMPROVES PRODUCTIVITY

- Luminous flux : 1020lm
- Charging time : 2H
- Equipped with 3 narrow beam LED bulbs to avoid dazzling
- Quality control for all surface preparation operations (coating, sanding and decoration)
- Rapid moving and positioning: no cumbersome wire to connect. Can be mounted on walls or ceilings up to 3 m high due to its screw-on extension pole
- Takes up very little floor space
- Stable pole attachment system

Manual or wired operation with the 3.5m cord supplied
Assembly in France

Case contents

	1 x 1378000 ErgoLiss® Cordless Inspection Lamp	p.40
	1 x 1378001 Inspection lamp charger (International)	
	1 x 1766100 OP Process® extension pole 2x1 m	
	1 x 1768080 Extension for OP Process® pole 2x1 m	
	1 x 3482000 Clip System® connector	



CHECK
OUT THE
VIDEO



More information on page 32

STEPS

07

08

PARFAITLISS'® LIGHT AND ROLLER SKIMMING KIT

NEW



80607

9-PIECE KIT FOR SMOOTHING COMPOUND New OP Process'® screwable range

Includes 2 new products :
ParfaitLiss'® Light Blade & bucket scoop

Case contents

	1 x 987220 Roll'Enduit® 220 mm	p.24
	1 x 1770220 OP Process'® Frame 220 mm	
	1 x 241025 ParfaitLiss'® Light 25 cm	p.29
	1 x 241045 ParfaitLiss'® Light 45 cm	
	1 x 241060 ParfaitLiss'® Light 60 cm	
	1 x 2599019 Bucket scoop 19 cm	p.38
	1 x 1769000 ParfaitLiss'® Connector	p.26
	2 x 1766070 OP Process'® extension pole 2x0,70 m	p.24



07 APPLYING



The high resilience of the fibre allows the plaster to be held in place without bedding it down and to be evenly distributed across the surface.

08 EMBEDDING



New handle up to 25% lighter
Reusable

Aluminium tip :
to balance the weight and combat wrist fatigue

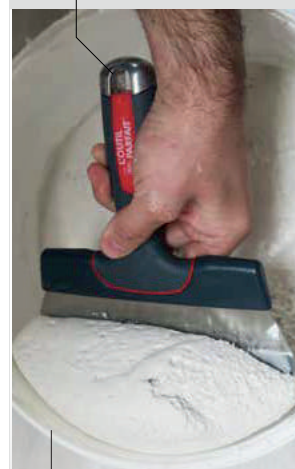

Smooth edge and flexible blade :
won't scratch the bucket

Also see page 38 for the 5kg bucket scoop. The oblique curve of the blade allows the hand to reach into the bucket.



More information on page 30

08 EMBEDDING



New handle up to 25% lighter
Reusable



New sponge :
CODE 582000

Its bevelled shape makes it easy to clean the plaster between the blade and the profile. Its small dimples leave no marks when drying. Its grip side won't scratch.

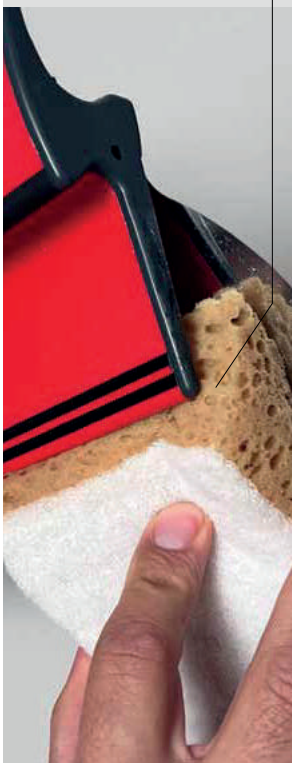

PREMIUM SMOOTHING KIT

NEW

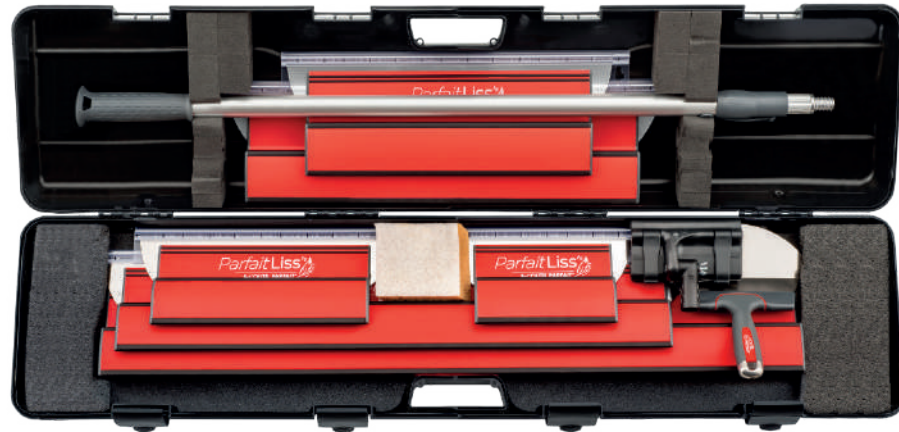

80636

FOR SMOOTHING LARGE AREAS

ParfaitLiss'@Light blade: smoothes at very high speed without loss of plaster, minimizing sanding work. New Soft Comfort anti-slip handle up to 25% lighter.

100% recyclable

Ergonomic, lightweight

Case contents

	1 x 241025 ParfaitLiss'@Light 25 cm	p.26
	1 x 241035 ParfaitLiss'@Light 35 cm	
	1 x 241045 ParfaitLiss'@Light 45 cm	
	1 x 241060 ParfaitLiss'@Light 60 cm	
	1 x 241080 ParfaitLiss'@Light 80 cm	
	1 x 241100 ParfaitLiss'@Light 100 cm	
	1 x 582000 Double-sided bevelled sponge	p.29
	1 x 1769000 ParfaitLiss'@ Connector	p.26
	1 x 1766100 OP Process extension pole 2x1 m	p.24
	1 x 2599019 Bucket scoop	p.38



CHECK
OUT THE
VIDEO



STEPS

08

STEPS

09

DUST FREE SANDING KIT



80488

74 PIECES KIT FOR FINISHING : SANDING EXCLUSIVE CONCEPT

Block mounted on high density foam allows easy and regular sanding, with integrated vacuum - Reduces the pressure to be exerted.

Head that can be moved in both directions: evenness and wide working range

Self-gripping abrasives - Quality: Anti-clogging
New self-sharpening ceramic grain mesh

Case contents

	1 x 1349000	Flat sanding vacuum block for pole attachment	p.34
	1 x 1350000	Corner sanding block for use with pole	
	1 x 1482100	ClipSystem® telescopic pole	
	1 x 1367000	Antistatic vacuum hose	p.35
	10 x 5396120	Sandpaper for flat sanding block Grain 120	
	10 x 5396180	Sandpaper for flat sanding block Grain 180	
	10 x 5396220	Sandpaper for flat sanding block Grain 220	
	10 x 5398120	Abrasive mesh for flat sanding block Grain 120	
	10 x 5398120	Abrasive mesh for flat sanding block Grain 120	
	10 x 5398120	Abrasive mesh for flat sanding block Grain 120	
	10 x 5398120	Abrasive mesh for flat sanding block Grain 120	
	10 x 5398120	Abrasive mesh for flat sanding block Grain 120	

CHECK OUT THE VIDEO



09 APPLYING



Vacuum up the particles using the suction hose and the hollow ErgoLiss® pole.



More information on page 36

NEW

WORKSTATION FOR PLASTERERS AND PAINTERS

The OP PROCESS[®] workstation carries all the necessary equipment and consumables.

- > From joint taping to painting
- > Handy and ergonomic, the OP PROCESS[®] Workstation follows you around the worksite.

CODE 80660 More information on page 33

**WORK
COMFORT**



PRODUCTIVITY

**STORAGE AND
TIDINESS ON
THE WORKSITE**

 CHECK
OUT THE
VIDEO

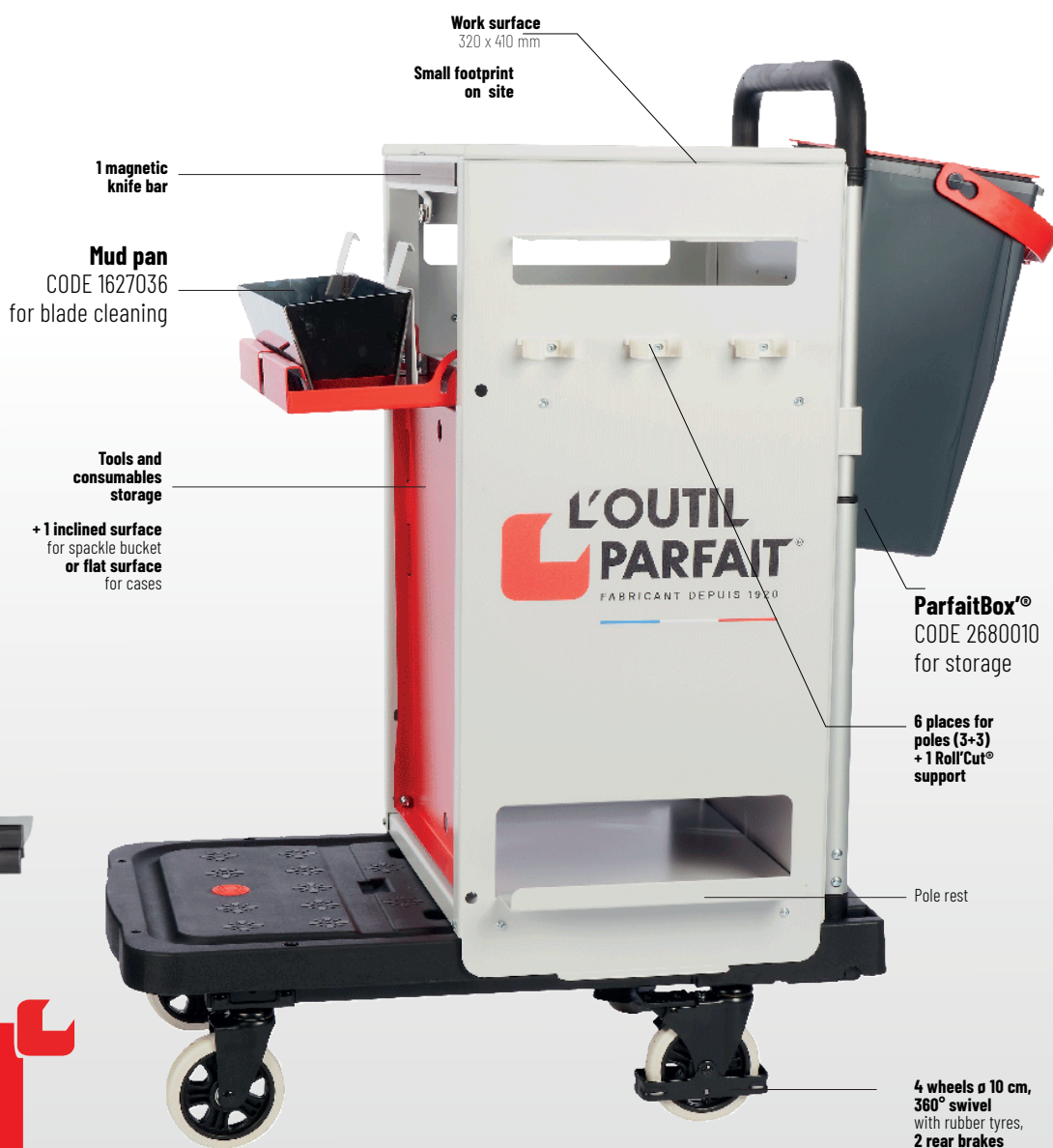

**CONFIGURATION
FOR THE PLASTER**





AN UNIVERSAL CONCEPT

FIRST PASS

SECOND PASS

01

APPLYING

02

LAYING

03

EMBEDDING

04

APPLYING

05

SMOOTHING

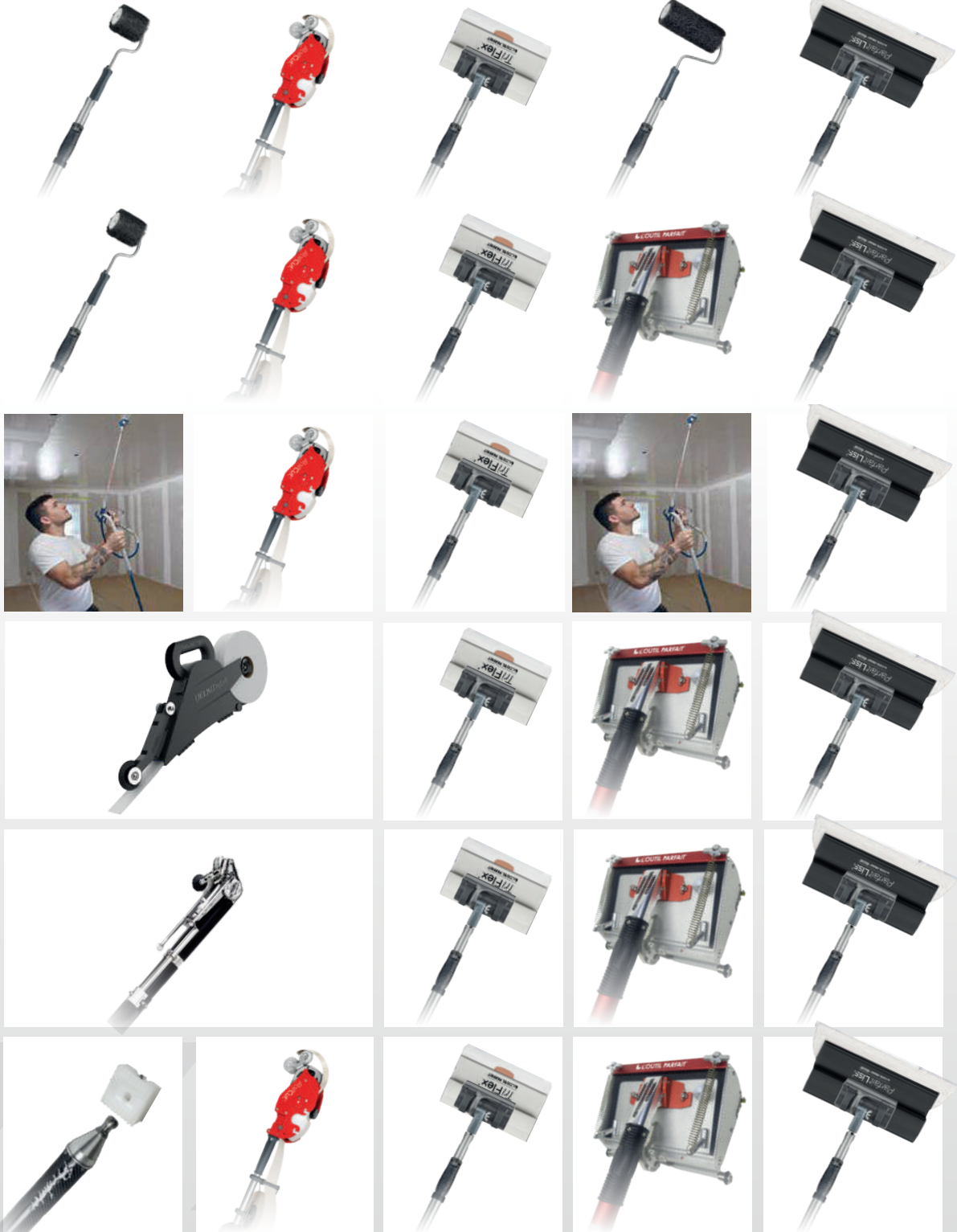

FINISHING BOXES COATING

AIRLESS SPRAYING

BANJO TAPER + FINISHING BOXES

AUTOMATIC TAPER + FINISHING BOXES

COMPOUND TUBE + FINISHING BOXES

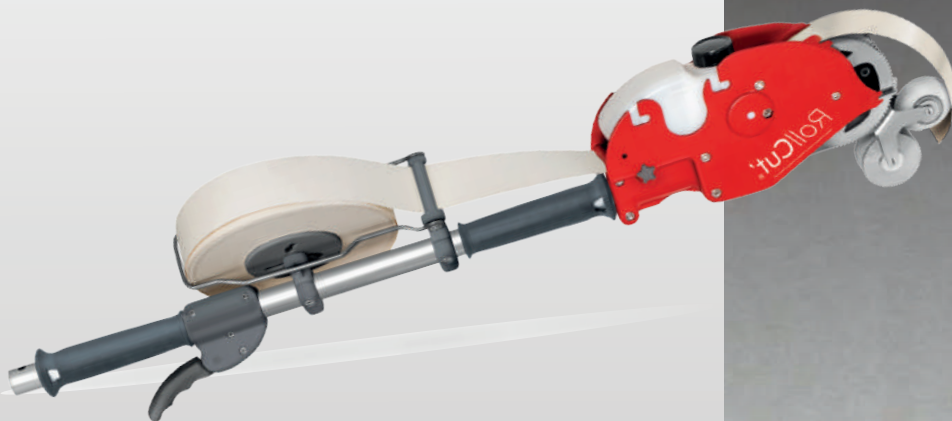

Roll'Enduit®	24
RollCut®	25
Triflex®	26
Embedding & Smoothing kits	27
ParfaitLiss® and kits	28 at 31
Cordless inspection lamp	32
OP PROCESS® Workstation	33
Dust free sanding	34 at 36
Mud Pan.....	38
Finishing joint knives	38
Plaster trowels.....	39
Flat boxes.....	40
Taping tools	41
Delko tools.....	42
Cutting tools.....	43 at 45
Plasterboard accessories	46
E.T.I.C.S.	47 at 50

OP PROCESS® TOOLS

STEPS

01

04

07

Roll'Enduit®

FILLER ROLLER : FROM JOINT TAPES TO WALLS AND CEILINGS

- Recommended Ready mixed compound, airless machine
- compound, roller applied compound

Specifications

- 18 mm nylon fibers
- High resilience
- 40 mm : with special reserve for corner
- 80 mm : 1st pass / Applying between tapered edges
- 180 mm : 2nd pass / Applying on both sides
- 220 to 400 mm: Coating large surfaces **(NEW)**



Roll'Enduit® sleeve

Size	CODE	
80 mm	987080	5
180 mm	987180	5
220 mm	987220	5
250 mm	987250	5
300 mm	987300	5
400 mm	987400	5
Sleeve corner		
40 mm	7987040	5



Roll'Enduit®

Size	CODE	
80 mm	2987080	1
180 mm	2987180	1
220 mm	2987220	1
250 mm	2987250	1
Roll'Enduit® Corner		
40 mm	1987000	1



OP Process® Frame

NEW

- Screw-on tip

Size	CODE	
40 mm	1770040	1
80 mm	1770080	1
180 mm	1770180	1
220 mm	1770220	1
250 mm	1770250	1



Frame connector

NEW

SCREW-ON POLE HEAD ANTI-ROTATION

- Screw-on tip

CODE	
3480000	1

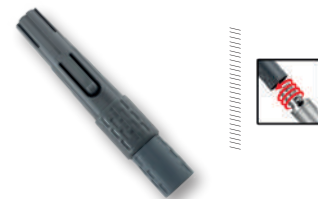

Adjustable frame

NEW

FOR 300 TO 500 MM SLEEVES

- With centring mark
- Screw-on tip
- Aluminium support

CODE	
1324000	1

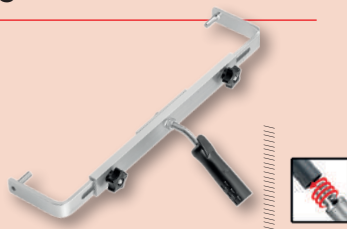

OP Process® extension pole

NEW

Specifications

- Screw-on male connector
- Telescopic 2 strands
- Aluminium tubes
- Rubberized handle
- Cam locking system for pole
- Anti rotation groove

Size	CODE	
2 x 0.7 m	1766070	6
2 x 1 m	1766100	6

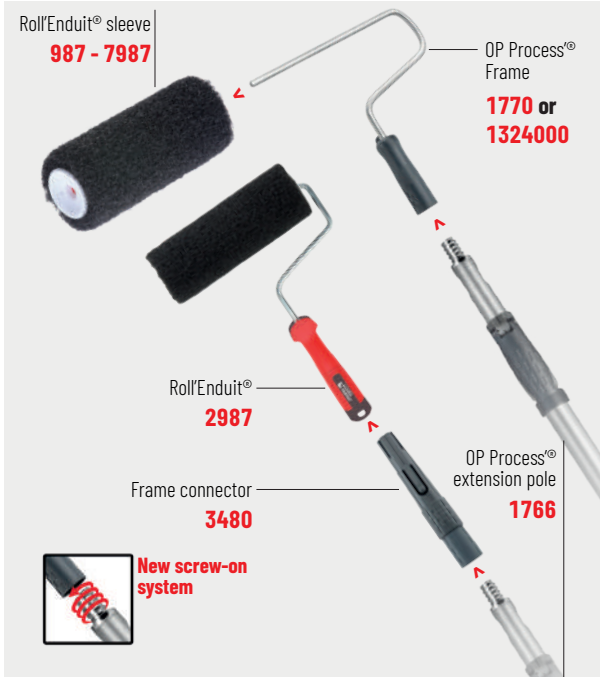

OP PROCESS®



Roll'Cut®

RollCut®



STEPS

02

OP PROCESS®

PAPER JOINT TAPE APPLICATOR : TO UNROLL, LAY AND CUT SUITABLE FOR LAYING ON WALLS AND CEILINGS, INCLUDING CORNERS

- Lightweight tool, mounted on extensions, to combat MSD
- Short version without extension for areas hard to reach such as cupboards
- Medium extension for vertical installation
- Long extension for laying in corners and high up
- Increased productivity guaranteed in addition to Roll'Enduit® and the entire pole-mounted range, or for Airless application
- The tape is moistened during application to limit bulging when drying

Specifications

- For 52 mm wide strips
- Precise head-integrated cutting, no pre-cutting, perfect joints, overlap-free connections
- 1 water tank consumed = 150 linear m of non-stop joint tape installation
- Supplied in carrying case 117x30x12 cm
- Net weight: just 3,5 kg
- **Patented**

CODE

3314000



1

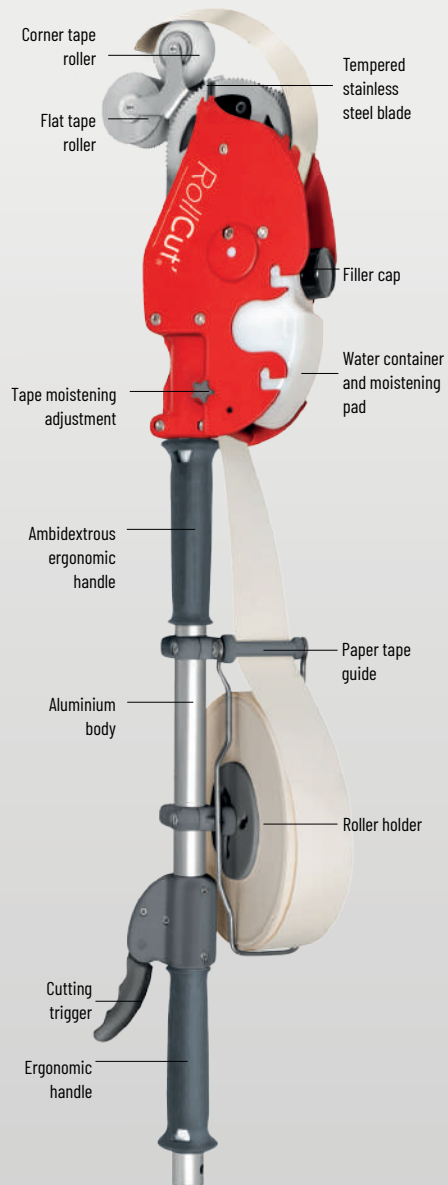

EMBEDDING

STEPS

01

TriFlex®

NEW

DOUBLE BLADE KNIFE RECOMMENDED FOR EMBEDDING

- TriFlex® technology : the central point of pressure provided by the rigid counter-blade, the straightness of the profile combined with the flexibility of the blade prevents wrist fatigue
- Recommended after using RollCut® Ref.3314

Specifications

- Soft blade 0.3 mm hardened stainless steel
- Manual use or with OP Process® pole Ref.1766 + ParfaitLiss® connector Ref.1769

Size	CODE	
24 cm	763024	2



OP Process® Corner flusher

NEW



THREADING HEAD TOOL FOR INSIDE CORNERS

Specifications

- Screw thread
- Hardened 0.5 mm stainless steel blade
- Flexible for 90° angle +/- 10°
- Mounted on ball-and-socket joint to choose your working angle

CODE	
3201000	1

ParfaitLiss® connector

NEW



FOR ALL PARFAITLISS® SKIMMING BLADES AND NEW EMBEDDING & WIPING DOWN TRIFLEX®

Specifications

- Spikes for plastering and stripping knives
- Fixing system with handle centring device
- System screw in centre
- Swivel head
- Fast, efficient locking system

CODE	
1769000	1

OP Process® ParfaitLiss® pole

NEW



LIGHT AND TELESCOPIC

Specifications

- Aluminium tube
- Swivel head
- Fast and efficient cam locking system
- Adjustment with Allen key 3 mm
- Anti rotation groove

Size	CODE	
2 x 0,50 m	3541050	1
2 x 1,00 m	3541100	1

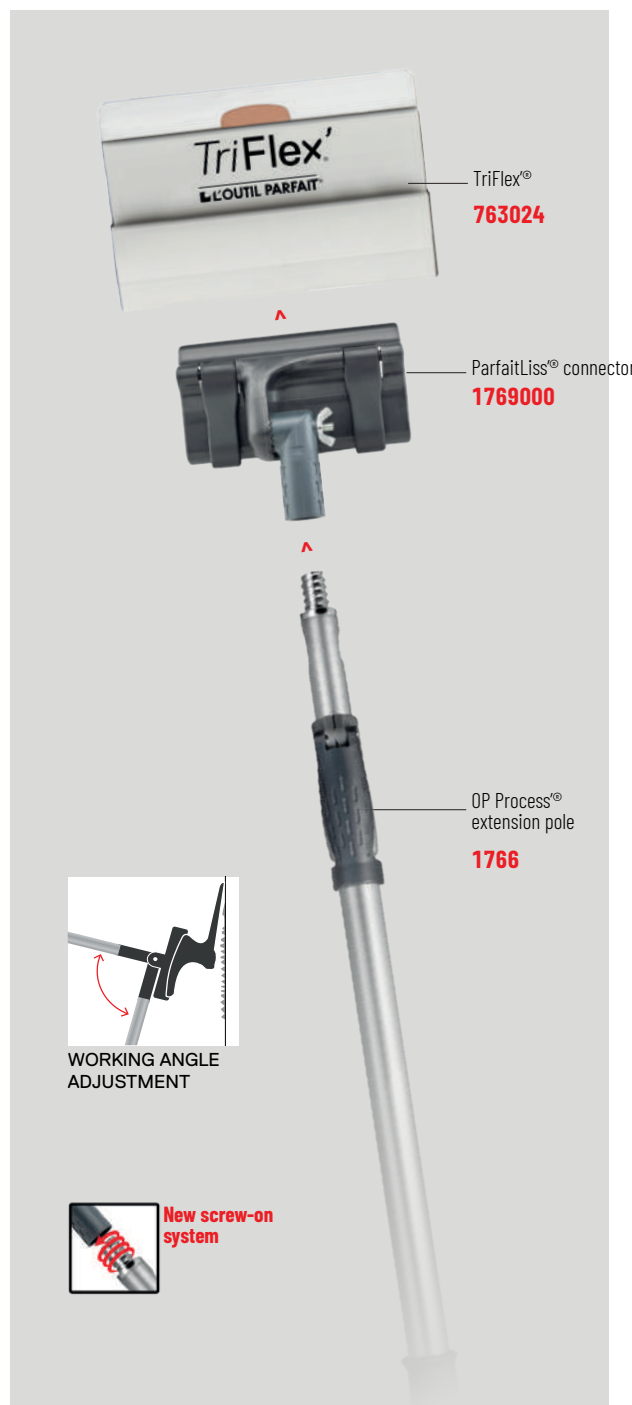



Taping Kit

NEW

COMPLEMENTARY TO FLAT BOXES AND AUTOMATIC TAPER AND BANJO

Specifications

- 6-piece kit :
 - 1 TriFlex®
 - 1 ParfaitLiss® Rigid 35 cm
 - 1 ParfaitLiss® Light 45 cm
 - 1 OP Process® Extension pole 2x0.7 m
 - 2 connectors OP Process® : 1 ParfaitLiss® + 1 Corner trowel
- Case : 82 x 30 x 85 cm

CODE



80606

1



STEPS

03

05

08

OP PROCESS'®

Joint Taping Set

NEW

NEW SCREW-ON OP PROCESS'® TOOLING CONCEPT

- Tooling with screw-on tip for the 1st and 2nd steps

Specifications

- 12-piece kit :
 - 1 ParfaitLiss® Rigid 35 cm
 - 1 TriFlex®
 - 2 OP Process® 2x0.70 m poles
 - 5 OP Process® Connectors :
 - 1 Corner trowel
 - 3 Roller frames (40, 80 and 180 mm)
 - 1 Parfaitiss®
 - 3 Roll'Enduit® plastering roller refills (Corner, 80 and 180 mm)
- Case : 82 x 30 x 85 cm

CODE



80624

1



STEPS

01

03

04

05

OP PROCESS'® Set

NEW

OP PROCESS'® TOOLING CONCEPT

Specifications

- 15-piece kit :
 - 2 ParfaitLiss® Light 45 and 60 cm
 - 1 ParfaitLiss® Rigid 35 cm
 - 1 TriFlex®
 - 2 OP Process® pole 2x1 m
 - 1 OP Process® pole 2x0.7 m
 - 5 OP Process® connectors :
 - 1 ParfaitLiss®
 - 1 Corner trowel
 - 3 Frames (40, 80 and 180 mm)
 - 3 Roll'Enduit® rollers refills (corner, 80 and 180 mm)
- Case : 105 X 30 X 11.3 cm



CODE



80625

1

STEPS

01

03

04

05

07

08

ParfaitLiss®

SMOOTHING WITHOUT BURRS

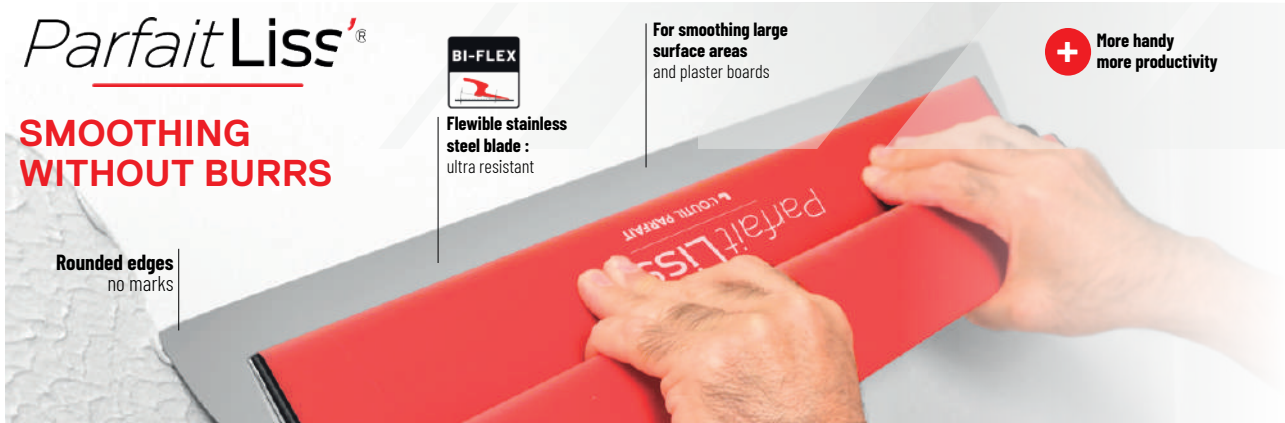

ParfaitLiss® smoothing blade

SMOOTHING OF SPRAYED COMPOUNDS, FINISHING AND SKIMMING WITHOUT BURRING
PERFECTLY HOMOGENEOUS SMOOTHING OVER THE ENTIRE BLADE LENGTH
ERGONOMIC, LIGHTWEIGHT

Specifications

- Flexible stainless steel blade, ultra resistant to abrasion
- Rounded edges for no marks
- High performance Bi-Flex technology blade with PVC counter blade

Size	CODE		Size	CODE	
2 cm	541002	2	25 cm	541025	2
4 cm	541004	2	35 cm	541035	2
6 cm	541006	2	45 cm	541045	2
8 cm	541008	2	60 cm	541060	2
10 cm	541010	2	80 cm	541080	1
12 cm	541012	2	100 cm	541100	1
15 cm	541015	2	120 cm	541120	1



ParfaitLiss® finishing kit

DEDICATED FOR PRECISION WORK

- Comes with a carrying case to wear on the belt

Specifications

- Composed of 6 ParfaitLiss® blades in 2, 4, 6, 8, 10 and 15 cm

CODE	
8898	1



ParfaitLiss® Roller Coating Kit

COMPLETE KIT FOR APPLYING AND SMOOTHING FILLERS

Specifications

- Contains :
- 1 Roll'Enduit® 180 mm
- 1 ParfaitLiss® 35 cm
- 1 Putty knife 10 cm

Recommended fillers : Ready-to-use fillers, Airless machine fillers, powder fillers under certain conditions.

CODE	
80617	1







2 NEW PARFAITLISS'®
THE PERFORMANCE OF THE ORIGINAL
BUT LIGHTER STILL





New Soft Comfort anti-slip handle
- Polypropylene and elastomer handle
- 25% lighter to improve dexterity compared to original ParfaitLiss'®
- Soft bands for greater comfort of use



Bi-Flex effect
The combination of the flexibility of the blade and the strength of the profile ensure perfectly uniform smoothness along the entire length

Hardened stainless steel blade

Progressive rounded edges

ParfaitLiss'® Light smoothing blade

NEW

- Smoothing sprayed plasters, finishing and burr-free raking of plasterboard and plaster strips
- Applying and finishing of decorative coating
- Use by hand or with the ParfaitLiss'® OP Process® Pole

Specifications	Size	CODE	
- Flexible stainless steel blade	25 cm	241025	2
- Ultra resistant to abrasion	35 cm	241035	2
- Recyclable polypropylene and elastomer handles	45 cm	241045	2
	60 cm	241060	2
	80 cm	241080	1
	100 cm	241100	1
	120 cm	241120	1



STEPS

08

ParfaitLiss'® Rigid

NEW

SMOOTHING AND RAKING OF HEAVY PLASTER AND PLASTERWORK

- New Soft Comfort non-slip handle
- Use by hand or with a ParfaitLiss'® OP Process® pole

Specifications	Size	CODE	
- Flexible stainless steel blade	25 cm	764025	2
- Ultra resistant to abrasion	35 cm	764035	2
- Recyclable polypropylene and elastomer handles	45 cm	764045	2
	60 cm	764060	2
	80 cm	764080	1
	100 cm	764100	1



STEPS

05

Double-sided bevelled sponge

NEW

- Designed for thorough cleaning of our ParfaitLiss'® and DécoLiss'® smoothing blades
- Does not scratch the blade

Specifications	CODE	
- Vegetable sponge with double bevels and double scrubbing/absorbent side - High absorption quality - One-handed spinning	582000	10



STEPS

07

08

ParfaitLiss® Light Skimming blades & Plastering roller Set



APPLYING AND SMOOTHING COATINGS

Applying and smoothing coatings

- New OP Process® screw-on tooling
- Includes 2 new features: ParfaitLiss® Light & bucket scoop for rapid setting of plaster in the bucket

Specifications

- 9-piece kit :
- 3 ParfaitLiss® Light skimming blades (25, 45 and 60 cm)
 - 2 OP Process® 2x0.7 m poles
 - 1 ParfaitLiss® Connector
 - 1 OP Process® Frame roller 220 mm
 - 1 Roll'Enduit® roller refill 220 mm
 - 1 Bucket scoop
- Case : 82 x 30 x 8.5 cm

CODE	
80607	1



Roller smoothing Kit

SPECIALLY DESIGNED FOR APPLYING AND SMOOTHING COMPOUNDS

VERY FAST FINISHING WITH NO LOSS OF PLASTER AND REDUCED SANDING WORK

Specifications

- 8-piece kit :
- 4 ParfaitLiss® skimming blades (10, 25, 45 and 60 cm)
 - 1 OP Process® ParfaitLiss® pole (2 x 0.70 m)
 - 2 OP Process® Roll'Enduit® (220 and 80 mm)
 - 1 OP Process® frame (2 x 0.70 m)
- Case : 82 x 30 x 8.5 cm

CODE	
80506	1



ParfaitLiss® Drywall worker Kit

COMPOSITION SPECIALLY DESIGNED FOR DRYWALL USE

SMOOTHING AND EMBEDDING PLASTERBOARD TAPES
VERY HIGH PRODUCTIVITY

Specifications

- 7-piece kit :
- 4 ParfaitLiss® (25, 35, 45 and 60 cm)
 - 1 OP Process® ParfaitLiss® pole 2 x 0.50 m
 - 2 Alu-choc® drywall knives (10 and 15 cm), one with screwing attachment
- Case : 82 X 30 X 8.5 cm

CODE	
80374	1





Premium Smoothing Kit

FOR SMOOTHING LARGE AREAS

Includes 2 new products :

- ParfaitLiss®Light Blade: smoothes at very high speed without loss of plaster, minimizing sanding work
- Bucket scoop for 17 kg bucket

Specifications

10-piece kit :
 - 6 ParfaitLiss®Light (25-35-45-60-80-100 cm)
 - 1 OP Process® 2x1m pole
 - 1 ParfaitLiss® Connector
 - 1 Bucket scoop
 - 1 Double-sided/double-bevelled sponge
 Case : 125 x 30 x 12 cm

CODE



80636

1



ParfaitLiss® Large surface kit

SPECIALLY DESIGNED FOR SMOOTHING AIRLESS COMPOUND FOR SMOOTHING AT VERY HIGH SPEED OVER LARGE SURFACE AREAS AND WITH NO LOSS OF PLASTER
 REDUCED SANDING WORK

Specifications

7-piece kit :
 - 6 smoothing blades (25, 35, 45, 60, 80 and 100 cm)
 - 1 OP Process® pole 2 x 1 m
 Case : 125 x 30 x 12 cm

CODE



80428

1



ParfaitLiss® Cement Airless coating kit

DESIGNED FOR WORKING WITH SPRAYING COATING ON CEMENT SUBSTRATES
 1 hard blade to quickly and efficiently sand across the surfaces before raking and smoothing with ParfaitLiss® on large surfaces and without loss of coating and without burrs.

Specifications

7-piece kit :
 - 5 ParfaitLiss® (25, 35, 45, 60 and 80 cm)
 - 1 ParfaitLiss®Rigid 60 cm
 - 1 OP Process® ParfaitLiss® pole 2 x 1 m
 Case : 105 X 30 X 11.3 cm

CODE



80427

1



Roller smoothing kit

APPLICATION & FINISHING KIT FOR FACADE/TOPPING COAT/CONCRETE/HEAVY COAT FOR EXTERIORS

- New: ParfaitLiss® Rigid 0.5 mm with new, lighter Soft Confort non-slip handle

Specifications

9-pieces kit :
 - 4 ParfaitLiss®Rigid (35, 45, 60 and 100 cm)
 - 1 ParfaitLiss® connector
 - 1 OP Process® frame 220 mm
 - 1 Roll'Enduit® sleeve 220 mm
 - 2 OP Process® poles 2x 1 m
 Case : 105 X 30 X 11.3 cm

CODE



80622

1



STEPS

06

Cordless inspection lamp kit

POWERFUL WIRELESS LIGHT FOR REAL-TIME DEFECT DETECTION IMPROVES PRODUCTIVITY

- Can be mounted on walls or ceilings up to 3 m high due to its screw-on extension pole
- Quality control for all surface preparation operations (smoothing, coating, sanding and decoration)
- Rapid moving and positioning: no cumbersome cable
- Mounted on a swivel fork : can be swivelled in all directions
- Stable pole attachment system
- Manual or wired use with the supplied 3.5 m cable

Specifications

- Luminous flux : 1020lm
- Colour temperature : 5700K
- Charging time : 2 hours
- Autonomy 5 hours
- Equipped with 3 narrow beam LEDs (15°) for glare-free operation
- Charging via mains cable included
- Lamp weight : 2.3 kg
- Dimensions : 36x45x12 cm
- CE certified
- OP Process® pole : 2 x 1 m + Extension 1 m
- New case : 105 X 30 X 11.3 cm

CODE	
80401	1



ErgoLiss® cordless inspection lamp

CHARGING TIME : 2 HOURS

Specifications

- Charger Input : 100-240v AC 50/60 Hz 0.35A Max
- Output : 16.8Vdc 1.5A
- With international electric adaptors

CODE	
1378000	1
Charger for inspection light	
1378001	1



ClipSystem® connector

CONNECTOR MADE OF TECHNICAL PBT MATERIAL, FILLED WITH GLASS BEADS FOR MECHANICAL STRENGTH

Specifications

- Screw-on head for OP Process® pole Ref. 1766
- Screw-on tip
- Female taper with lug fixing system

CODE	
3482000	1

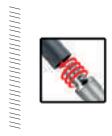

OP Process® extension pole

Specifications

- Screw-on male connector
- Telescopic 2 strands
- Aluminium tubes
- Rubberized handle
- Cam locking system for pole

Size	CODE	
2 x 1 m	1766100	6



Inspection lamp stick

EXTENSION FOR SCREW-ON SYSTEM POLE PART CODE 1766100 FOR CORDLESS INSPECTION LIGHT CODE 1378000

Specifications

- End cap with Acme screw thread
- 1 strand
- Aluminium tubes

Size	CODE	
1 m	1768080	6





OP Process® Workstation

WORKSTATION FOR THE PLASTERER AND PAINTER SUPPLIED WITH CART TROLLEY CODE 1760001

- The OP Process® trolley can carry all the equipment and consumables required for the following tasks
- From joint tape application to painting
- Handy and ergonomic, the Workstation follows you around the worksite

Specifications

Composed of :

- **1 Folding handling cart :**

- 4 Ø110 cm 360° swivel wheels with rubber tyres
- 2 rear brakes
- Tray dimensions: 67 x 41 cm
- Payload: 137 kg

- **1 ParfaitBox®**

- **1 Coating tray**

- **1 Metal box :**

- Work surface 32 x 41 cm
- Storage space for consumables
- Storage space for tools
- Inclined surface for spackle bucket and paint hopper
- 6 places for poles (3 + 3)
- RollCut stand
- Smoothing blade holder
- space for plaster pan
- Magnetic knife clip
- Joint tape roll holder

Total weight Cart + Servant: 22kg

CODE



80660

1



CHECK OUT THE VIDEO



Easily transport your OP PROCESS® tools and cases from truck to job site.



Store and transport your bucket of filler, paint can or ParfaitBox® for the next day !



Your plaster pan does not move when your blade is trimmed. Place your ParfaitLiss® behind the metal hooks between uses.

STEPS

09

DUST FREE SANDING SYSTEM

High density pad for easy and even sanding, reducing the pressure



Multiposition head

New ceramic mesh

Sandpaper particularly suitable for lightweight plasters

Built in dust vacuuming



Hose to vacuum cleaner
CODE 1367

Corner sander on pole

FOR FINISHING INSIDE CORNERS AND EDGES AT A HEIGHT
PRECISE, DUST-FREE WORK

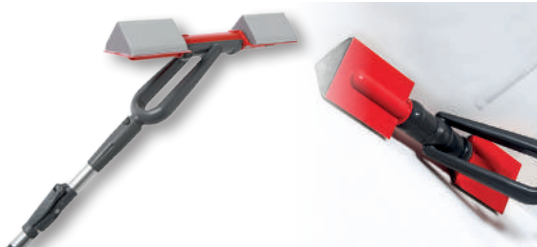

Specifications

- Composition :
- 1 corner sanderblock 140 x 120 mm
 - 1 Telescopic aluminium pole 2x1 m
 - Sandpaper not supplied

CODE 
80322 2

Flat sander on pole

FOR FINISHING FLAT SURFACES AT HEIGHT
PRECISE, DUST-FREE WORK



Specifications

- Composition :
- 1 flat sander 20 x 20 cm, with built in dust vacuuming
 - 1 aluminium pole 2x1 m
 - Rubber grip tip and quick cam fastening
 - Paper not supplied

CODE 
80321 2

Corner sander

TO BE CONNECTED TO THE
ERGOLISS® POLE
CODE 1482

Specifications

- Sandpaper not supplied

CODE 
1350000 1

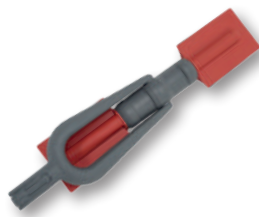

Flat sanding

TO BE CONNECTED TO THE
CODE 1482 POLE

Specifications

- Sandpaper not supplied

CODE 
1349000 1

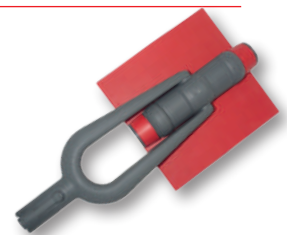

Antistatic vacuum hose

UNIVERSAL AND SEALED SUCTION CONNECTION
ANTISTATIC - FLEXIBLE - LIGHTWEIGHT

Specifications

- Length: 5 m
- Tapered rubber connection at the suction end
- External diameters of ferrules :
* 35 to 60 mm vacuum connection side
* 30 to 40 mm on pole side
- For connection to ErgoLiss® pole code 1482



CODE 
1367000 1

ErgoLiss® pole

UNIVERSAL POLE

Specifications

- Aluminium tubes
- Female tapered head with pin fixing system
- Cam locking system for the pole: fast and efficient
- Suction boom compatible with the suction gose code 1367



CODE 
1482100 1



Hybrid flat sander

SANDER MOUNTED ON A HIGH DENSITY PAD FOR EASY AND EVEN SANDING
REDUCES THE PRESSURE REQUIRED

Specifications

- Self adhesive face
- Foam handle
- Dimensions: 20 x 20 cm
- Supplied without sandpaper

Remove one of the two plugs to connect the vacuum

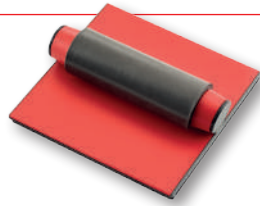

CODE 
1357000 1

Hand corner sander

FOR FINISHING INSIDE CORNERS AND EDGES - FOAM MOUNTING ALLOWS EASY AND EVEN SANDING AND REDUCES THE AMOUNT OF PRESSURE REQUIRED

Specifications

- Self-adhesive face
- Quick to use
- Foam handle
- Dimensions: 2 wedges 140 x 120 mm
- Supplied without sandpaper

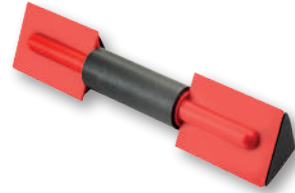

CODE 
1360000 1

Flat sander spare pad

REPLACEMENT FOAM FOR FLAT SANDER CODE 1357000 AND 1349000

- Self-gripping on 2 sides : quick and easy changeover

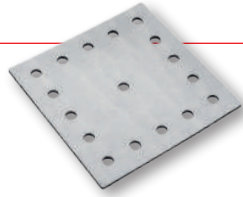

CODE 
1382000 1

Corner sander spare pad

REPLACEMENT FOAM FOR CORNER SANDING BLOCKS CODE 1350000 AND 1360000

- Self-gripping on 3 sides : quick and easy changeover

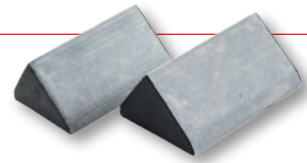

CODE 
1389000 1

Sandpaper for flat sander

SPECIAL COATINGS AND FINISHING WORK

- Quality : Anti-clogging
- Quick installation thanks to the Velcro fastening system





Specifications	Grain	CODE	
- 10 sandpapers	120	5396120	5
- Dimensions: 20 x 20 cm	180	5396180	5
	220	5396220	5
	Sanding Mesh		
	120	5398120	5

Sandpaper for corner sander

SPECIAL COATING AND FINISHING WORK

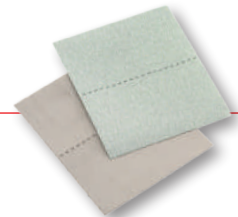
- Anti-clogging quality
- Self-gripping : Quick and easy changing
- For corner sander code 313000



Specifications	Grain	CODE	
- 10 Sandpapers	120	5392120	5
- Dimensions: 12 x (2 x 7.5) cm	180	5392180	5
	Sanding Mesh		
	120	5399120	5

Hand Corner sander

MANUAL USE
ERGONOMIC GRIP FOR EASY SANDING OF CORNERS

- Self-gripping: quick and easy changing



Specifications

Size	CODE	
72 X 246 mm	313000	2

- Firm foam with glued velcro tape
- Supplied without sandpaper
- Dimensions: 72 X 246 mm

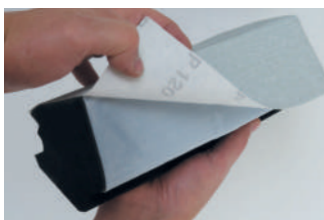

Sandpaper for corner sander

SPECIAL COATINGS - FINISHING WORK

- Anti-clogging quality
- Self-gripping : Quick and easy changing
- For corner sander code 313000

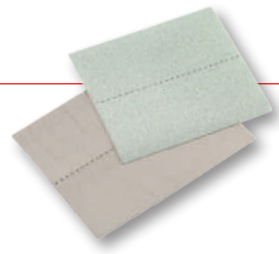

Specifications

Size	CODE	
Sandpaper		
120	5315120	5
180	5315180	5
Sanding Mesh		
120	5316120	5

- 10 sandpapers
- Dimensions : 250 x 150 mm

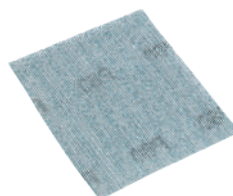

STEPS

09

Dust-free sanding kit

FOR FINISHING : SANDING EXCLUSIVE CONCEPT

- Extra comfort and efficiency
- Wide working range thanks to the adjustable head of the sanders

Specifications

CODE	
80488	1

74-piece kit :

- 2 sanders for pole : 1 flat / 1 corner
- 1 Pole + 1 hose to vacuum cleaner
- 30 Flat sandpapers : 120 / 180 / 220 grit + 10 Mesh 120 grit
- 20 Corner sandpapers: 120 / 180 grit + 10 Mesh 120 grit
- Case : 117 x 30 x 12 cm



**USE THE INSPECTION LAMP DURING
SANDING FOR A PERFECT FINISH**

CODE 80401
P32



NEW CASE

OP PROCESS®



BOOST YOUR PERFORMANCE WITH CUSTOMIZED MERCHANDISING



The Export team can help you optimize your shelf layout and product presentation to maximize sales and reinforce your brand image.

Contact us and find out how we can help you maximize the potential of your outlets.

Mud pan



FOR KNIVES AND SMOOTHING BLADES UP TO 30 CM

- Rounded bottom for easy handling and cleaning
- Non-slip, insulating grip zone

Specifications	Size	CODE	
- Stainless steel tray, thickness 0.70 mm	36 cm	1627036	5
- Height 9 cm			
- 31.8 cm base flared to 35.8 cm			
- Width 6.5 cm flared to 10.8 cm			

Half moon knife



FOR 90° AND 30° CORNERS

Specifications	Size	CODE	
- Tempered stainless steel blade	15 cm	2615015	5
- Ergonomic bi-material handle			

Joint knife



ALUMINIUM END CAP WITH HOLE FOR TAPPING ERGONOMIC AND BALANCED SHAPE	Size	CODE	
	2 cm	2613002	5
	4 cm	2613004	5
	6 cm	2613006	5
	8 cm	2613008	5
	10 cm	2613010	5
	12 cm	2613012	5
	15 cm	2613015	5
	25 cm	2613025	5
	Joint knife with bit		
	10 cm	2783010	5
	15 cm	2783015	5



Bucket scoop

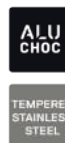

ROUNDED BLADE FOR FASTER PLASTER SETTING

- Curved for hand release

Specifications	Size	CODE	
		For 17 kg bucket	
- 0.5 mm stainless steel blade, Overmoulded	19 cm	2599019	5
- Flexible blade to avoid scratching the bucket		For 10 kg bucket	
- Ergonomic bi-material handle	10 cm	2594010	5
- Aluminium hammer cap to balance weight			

Corner cambered knife



PLASTERER'S KNIFE CURVED FOR EASY HAND CLEARANCE FROM THE SURFACE.

POINTED FOR A PERFECT ANGLE.

Specifications	CODE	
- Tempered stainless steel blade	2589090	5
- Ergonomic bi-material handle		

Set of joint knives



IDEAL COMPOSITION FOR TAPING PLASTERBOARD JOINT

Specifications	CODE	
Composition : - 1 multipurpose scraper - 7 flexible knives in 2, 4, 6, 8, 10, 12 and 15 cm - Tempered steel blade	2433000	1

Set of joint knives



IN PLASTIC CASE

Specifications

- Contains:
- 5 tapping knives (8, 10, 12, 15 and 25 cm)
- 1 multipurpose 6 in 1 scraper

CODE	
80117	1



Bi-Flex Finishing Trowel



TEMPERED STAINLESS STEEL

BI-FLEX TECHNOLOGY

- Gradually progressive rounded edges and corners to leave no trace
- Concave base to compensate for plaster shrinkage
- 40% lighter

Specifications	Size	CODE	
- Tempered stainless steel blade	30 x 11 cm	1718028	1
- Thickness 0.4 mm	35 x 11 cm	1718035	1
- Double row of rivets			
- Rubberised handle for comfort, polycarbonate handle for rigidity and lightness			
- Patented			

Double blade Finishing trowel



TEMPERED STAINLESS STEEL

FOR FINISH PLASTERBOARD TAPES AND SURFACES

- Flat smoothing, with no material removal
- Supplied in a durable protective case

Specifications	Size	CODE	
- Tempered stainless steel blade	30 x 11 cm	1725030	1
- Thickness 0.3 mm	35 x 11 cm	1725035	1
- Bi- material polycarbonate soft handle	40 x 11 cm	1725040	1
- Bi-flex double blade technology	45 x 11 cm	1725045	1
- Patented			

Double blade Finishing trowel



TEMPERED STAINLESS STEEL

FLAT SMOOTHING, WITH NO MATERIAL REMOVAL

Specifications	Size	CODE	
- Tempered stainless steel blade	30 X 11 cm	1726030	1
- Thickness 0.3 mm	35 X 11 cm	1726035	1
- Ergonomic composite handle	40 X 11 cm	1726040	1
- Lightweight aluminium frame	45 X 11 cm	1726045	1
- Bi-flex double blade technology			

Drywall/Masonry trowel

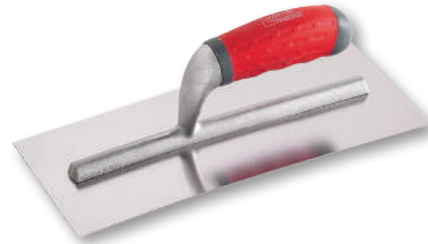

STAINLESS STEEL

RECTANGULAR STAINLESS STEEL CURVED BLADE

- The curved shape allows for better loading into board joints

Specifications	Size	CODE	
- Stainless steel blade	28 x 12 cm	1717000	1
- Thickness 0.6 mm			
- Straight angles			
- Ergonomic composite handle			
- Lightweight aluminium frame			
- Patented			

Inside trowel



STAINLESS STEEL

PERFECT, FAST CREATION OF INSET CORNERS

- Unbreakable striking tip and index protection

Specifications	CODE	
- Stainless steel blade	2104000	1
- Composite handle		
- Patented		

Outside trowel



STAINLESS STEEL

PERFECT, FAST OUTGOING CORNER CREATION







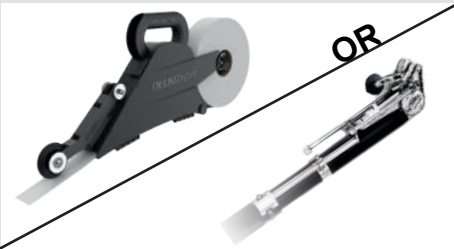

- Unbreakable striking tip and index finger protection

Specifications	CODE	
- Stainless steel blade	2105000	1
- Composite handle		
- Patented		

FLAT BOX

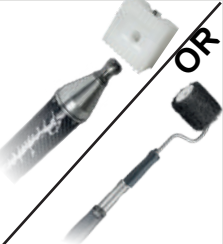
For finishing, even work.

Spare parts kit: contact us

	FIRST PASS			SECOND PASS	
	01 APPLYING	02 LAYING	03 EMBEDDING	04 APPLYING	05 SMOOTHING
TAPER + FINISHING BOXES	 OR				
COMPOUND TUBE + FINISHING BOXES	 OR				

Automatic finisher box

NEW

FLAT JOINTS

- Mechanised finishing box for loading and finishing joint tapes on plasterboard

Specifications	Size	CODE	
- High-quality anodised aluminium	20cm / 8"	3740020	1
- Adjustable flow of filler or finish coat	25cm / 10"	3740025	1
- Filling with Delko plaster pump Part No.3054000	30cm / 12"	3740030	1



Extendable finisher box handle

NEW

Specifications	Size	CODE	
- Telescopic aluminium handle	101-152cm/	3741150	1
- Ergonomic handle	40-60"		
- Mechanical braking			





42" Compound Tube

NEW



FOR MUD APPLICATORS PART NO. 3743 OR DIRECT CORNER FLUSHER PART NO. 3746000

Specifications	Size	CODE	
- Aluminium and stainless steel - Self-lubricating piston bushing - semi-automatic cone fitted with a spool with brake	106cm/42"	3742000	1

Teflon Mud Applicator

NEW

- For Compound Tube Part No.3742000

Specifications

- 2 compound outlets
- Clip fixing



	Size	CODE	
Flat		3743001	1
Inside Corner		3743002	1
Outside Corner		3743003	1

OP Process® extension pole

NEW



Specifications	Size	CODE	
- Screw-on male connector	2 x 0.7 m	1766070	6
- Telescopic 2 strands	2 x 1 m	1766100	6

Use OP Process® extension pole for screw-on corner roller

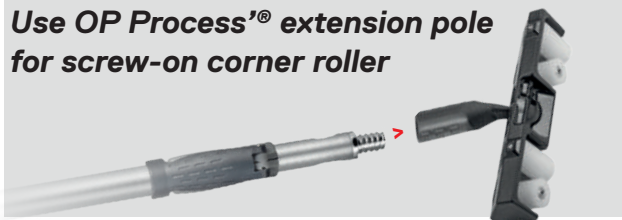

Inside corner roller

NEW

CODE	
3946000	1

Specifications

- Innovative split wheel design
- Cast aluminum body
- Hand made from U.S. aluminum and steel components



3" Direct Corner Flusher

NEW

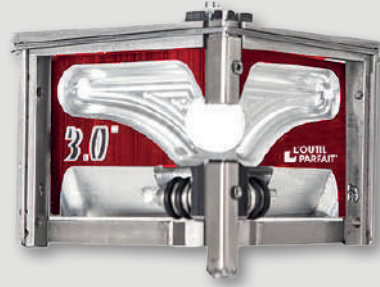

SMOOTH AND TIGHTEN

- Smooth and tighten after using Roll'Enduit® Corner
- Or apply the coating simultaneously using the Compound Tube (Part No.3742000)
- Recommended for the 2nd pass

Specifications	Size	CODE	
- Anodised aluminium body - Stainless steel frame - Locking clip system - Includes: wheels and Allen key	7,5cm/3"	3746000	1

2,5" Standard Corner Flusher

NEW



- After using corner filer roller code 7987040 or after using the Compound Tube (code 3742000) with the Inside Corner Teflon Mud Applicator (code 3743002)
- To be used with pole code 1766.

Specifications	Size	CODE	
- Aluminium head - Stainless steel body - Locking clip - Includes wheels and Allen key	6,5cm/2,55"	3745000	1

Screw-on corner roller



FOR USE JUST AFTER THE AUTOMATIC GLUEING TOOL SO THE ROLLER PUSHES THE JOINTING TAPE INTO THE CORNER ESSENTIAL PRIOR TO USING THE CORNER FINISHER

Specifications	CODE	
- Screw-on handle for OP Process® pole CODE 1766	Inside corner	
- Steel frame with ball joint	2946000	1
- 4 non-marking nylon wheels	External corner	
	2948000	1

Delko Hybrid Taper

NEW



APPLIES PLASTER AND TAPE SIMULTANEOUSLY

- Bi-material central handle
- Velcro comfort side handle
- Quick access to reloading hooks

Specifications

- Compatible with rolls of paper tape up to 150 m
- Coating capacity up to 2.25 kg
- Lever for adjusting coating flow
- Patented double-head applicator

CODE

3014000



1

Zunder tape coater

APPLIES PLASTER AND TAPE SIMULTANEOUSLY

- For flat areas and corners
- Soft main handle and 2 velcro adjustable side handles
- Quick reloading access via single hook and hinges

Specifications

- Can be used with jointing tape rolls up to 150 m
- Coating capacity approx. 2.2 kg
- Lever to adjust flow of coating
- Double wheel for flat areas and corners
- Soft main handle
- 2 velcro-adjustable side handles

CODE

3214000



1



Delko Filler Pump

NEW

FOR FINISHING PLASTERS AND READY-TO-USE PLASTERS

- For finishing plasters and ready-to-use plasters
- For fast, mechanical filling of the Delko® filler Ref.3014000

Specifications

- 1.1 litre capacity
- Flat nozzle
- Single non-slip rubber handle
- Removable for thorough cleaning

CODE

3054000



1



Delko Turbo mixing paddle

SPECIAL MIXING PADDLE FOR FINISHING PLASTERS AND READY-MIXED PLASTERS

- For use with an corded or cordless drill or with a mixer using adaptor CODE 826000

Specifications

- Mixing paddle with highly flexible and durable rubber blade
- Ø10 mm hexagonal spindle

CODE

3055000



1



Mixing paddle

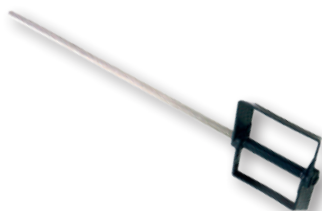

FOR MIXING PASTE-LIKE AND VISCOUS PRODUCTS

- LATERAL VORTEX effect : increases the homogeneity of the coatings, avoids air bubbles and reduces the drying time

Specifications

- Stainless steel hexagonal shaft Ø10
- Polypropylene blade Ø170 mm
- Mixed quantity: from 10 to 50 kg

Length

560 mm

CODE

825000



1

M14 adapter



MIXING PADDLE ADAPTER WITH HEXAGONAL SHAFT Ø10 FOR MIXER THAT ACCEPTS ONLY M14 CONNECTOR

Specifications

- For mixing paddle pulp products Ref. 825000

CODE

826000



1



Plasterboard saw



SPECIALLY DESIGNED TOOTHING FOR QUICK CLEAN CUTS IN DRYWALL AND PLASTERBOARD

- Saw with American teeth - Precise and fast
- Double teeth : small teeth at the end (precision line at the beginning of the cut) and large teeth (fast sawing of board)

Specifications	Size	CODE	
- Hardened G77 teeth with clearance groove	550 mm	3066000	1
- Two-component handle			
- 90° and 45° angles integrated in the handle			

Jab saw double cutting



DOUBLE-EDGED BLADE : EASIER HANDLING WHEN CUTTING

Specifications	Size	CODE	
- Trident point for cutting starters or before holes	180 mm	3110180	1
- Tothing : staggered double row	250 mm	3110250	1
- Triple bevel			
- Ergonomic bi-material handle			
- Sheath included			

Plastering cutter 18 mm



GOOD GRIP, ERGONOMIC, COMFORTABLE, SECURE USE

Specifications	CODE	
- 18 mm snap-off blade	3133000	12
- Metal blade guide	Cutter blade 18 mm - BOX OF 10	
- Bi-material body	931000	20
- Anti-return quick lock		

Metal plane

FOR PLANING THE EDGES OF PLASTERBOARD



Specifications	Size	CODE	
- Zinc alloy body	42 x 275 mm	2683000	1
- Front support handle for greater precision		Metal blade	
- Includes: 1 flat metal rasp	42 x 250 mm	2687000	1
- Interchangeable rasps CODE 2687			

Jab Saw



FOR CUTTING PLASTERBOARD, WOODEN PANELS, ETC

- Diamond surfacing on 3 ultra-sharp cutting edges - Very rigid
- Sharp point

Specifications	Size	CODE	
- Double serrated blade for directional cutting	160 mm	1513000	1
- 8TPI serration			
- Ergonomically designed two-component handle			

Plastering cutter 25 mm



FOR PLASTERBOARD

Specifications	CODE	
- 25 mm snap-off blade	152000	6
- Thickness 0.70 mm	Cutter blade 25 mm - BOX OF 10	
- Bi-material body with metal blade guide	158000	10

Plastering Cutter 9 mm



GOOD GRIP, ERGONOMIC, COMFORTABLE, SECURE USE

Specifications	CODE	
- 9 mm snap-off blade	3131000	12
- Bi-material body with metal blade guide	Cutter blade 18 mm - BOX OF 10	
- Anti-return quick button	929000	10

Sanding block

FOR PLASTERBOARD SANDING



Specifications	Size	CODE	
- Abrasive mesh fastening by screw clamping	105 x 230 mm	2942000	1
- HD foam handle and sole with a foam sub-layer		Mesh for sanding block - BOX OF 50	
- Supplied without abrasive mesh			

Special plasterer's screwdriver bit holder

TRANSFORMS YOUR CONVENTIONAL SCREWDRIVER INTO A PROFESSIONAL PLASTERER'S SCREWDRIVER



Specifications	CODE	
- Powerful magnet	3003000	1
- Interchangeable tip		
- Unscrewing mode		

CUTTING TOOLS



Forged aviation Snip

HIGH-STRENGTH STEEL BLADES

Specifications

- Lever action
- Cuts up to 35 mm in one press in gauges of 1.5 mm for soft sheets and 0.9 mm for stainless steel sheets
- Soft touch non-slip grips with guard to protect user's finger

Size	CODE	
225 mm	1212000	1



Forged aviation Snip

32 CM STRAIGHT SNIPS FOR STUDS, PROFILES, THRESHOLD STRIPS MADE OF STEEL, ALUMINIUM, ZINC, PLASTIC, GALVANISED, ETC.

- Specially designed for difficult cuts

Specifications

- Micro-serrated blades
- Soft touch grips guard to protect finger
- Latch system, spring action, lever action
- Cutting capacity : stainless steel 0.8 mm / soft metal 1.2 mm

Size	CODE	
320 mm	1202000	1



Crimping pliers for rails and uprights

FOR CRIMPING ALL TYPES OF RAILS AND POSTS (ALSO FOR RAILS AND FITTINGS, F530, ...)

- Articulated head

Specifications

- Max. capacity : 1 + 1 mm - For right and left setting
- Soft touch non-slip handle with finger guard to protect the user's finger

Size	CODE	
255 mm	1777000	1



Nibbling shears

DISTORTION-FREE CUTTING

- Allows circular cuts

Specifications

- High strength steel blades
- Soft touch non-slip handle with finger guard
- With integrated chip cutter
- Openings and cut-outs in : galvanised, zinc, soft sheet metal up to 1.2 mm; copper, brass up to 1.5 mm; PVC, vinyl tile, aluminium up to 2 mm

Size	CODE	
275 mm	1210000	1



Multi-cutting mitre pliers

MULTIFUNCTIONAL : PVC STRIP CUTTER, DECORATIVE MOULDINGS, RIGID PLASTERBOARD STRIP

Specifications	Size	CODE	
- Multi-angle 45° - 135° adjustable - Soft-touch non-slip handle	225 mm	1776000	1



Crimping section setting pliers for studs & tracks

FOR CRIMPING ALL TYPES OF STUDS AND TRACKS (ALSO FOR RAILS AND FITTINGS, F530, ETC.)
ARTICULATED HEAD

Specifications	Size	CODE	
- Max capacity 1 + 1 mm - For right and left setting - Soft touch non-slip grips with finger guard to protect the user's finger	330 mm	3007000	1



Profile crimping pliers for studs & tracks

FOR CRIMPING STUDS & TRACKS WITHOUT SCREWS OR RIVETS

Specifications	Size	CODE	
- Maximum capacity 0.8 + 0.8 mm - Soft touch non-slip handle with finger guard to protect the user's finger	340 mm	1214000	1



Crimping pliers for studs and tracks One hand section setting

FAST FIXING BY PUNCHING

Specifications	Size	CODE	
- Maximum capacity 0.6 + 0.6 mm - Spring return - Soft touch non-slip handle with finger guard	270 mm	3015000	1



Metal anchor setting tool

FOR HOLLOW WALLS - EASY TO USE IN CORNERS
- COMPACT DESIGN

Specifications	Size	CODE	
- Easy to release by pushing the handle in the opposite direction - 5-step rack system - For anchor Ø8 mm - Pulling travel of 30 mm - Soft touch non-slip handle with finger guard	180 mm	1213000	1



Plasterboard lifter

ADJUSTABLE PLATE SUPPORT FOR VERTICAL, WALL-MOUNTED OR INCLINED INSTALLATION IN SLOPING ROOFS
2 EXTENDABLE PLASTERBOARD SUPPORTS WITH 3 POSITIONS

Specifications

- Maximum load: 68 kg
- Installation height: maximum 3.35 m
- Tripod with castors
- Frame with telescopic rod
- 60° tilt and 360° horizontal swivel plate support
- Automatic brake
- **Prevention of musculoskeletal disorders (MSD)**
- **CE standard**

CODE 
3191000 1



Board carrier handles

SET OF 2 HANDLES FOR CARRYING 2 BOARDS BETWEEN 2 PEOPLE

Specifications

- Steel Ø15 mm
- With non-slip rubber sleeve
- Dimensions: 160 x 130 mm
- Reversible for right- and left-handed use
- Prevention of MSD (Musculoskeletal disorders)

CODE 
3098000 1



Plasterboard transporter

ROD HANDLE FOR ONE-PERSON TRANSPORT OF BOARDS AND PANELS
ERGONOMIC POSITION

Specifications

- Ø12 mm steel rod
- Galvanised finish
- Height 50 cm
- Wide 175 mm base plate
- Prevention of musculoskeletal disorders (MSD)

CODE 
3103000 1



Board holder

TILT SYSTEM : FOR PRECISE POSITIONING OF THE BOARD OR INSULATION WHILE SCREWING INTO THE FRAME

Specifications

- Epoxy finish steel shaft
- 13 x 15 cm shoe in glass-fiber reinforced polyamide
- 13 mm bevelled tab
- MSD prevention (musculoskeletal disorders)

CODE 
3101000 1



Stirrup lifter

FOR LIFTING AND PLACING PLASTERBOARDS
ALSO IDEAL FOR LIFTING DOORS

Specifications

- Steel
- Tilt system : precise positioning for screwing the board into the frame
- Prevention of MSD (Musculoskeletal disorders)

CODE 
3099000 1

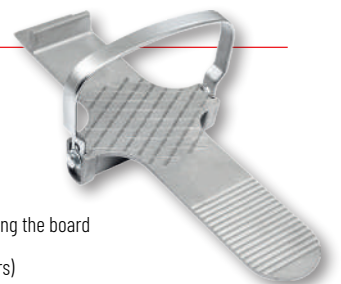

A COMPLETE RANGE FOR LAYING EXTERIOR INSULATION

L'Outil Parfait's E.T.I.C.S tooling solution is ideal for insulating materials designed to improve and limit energy consumption.

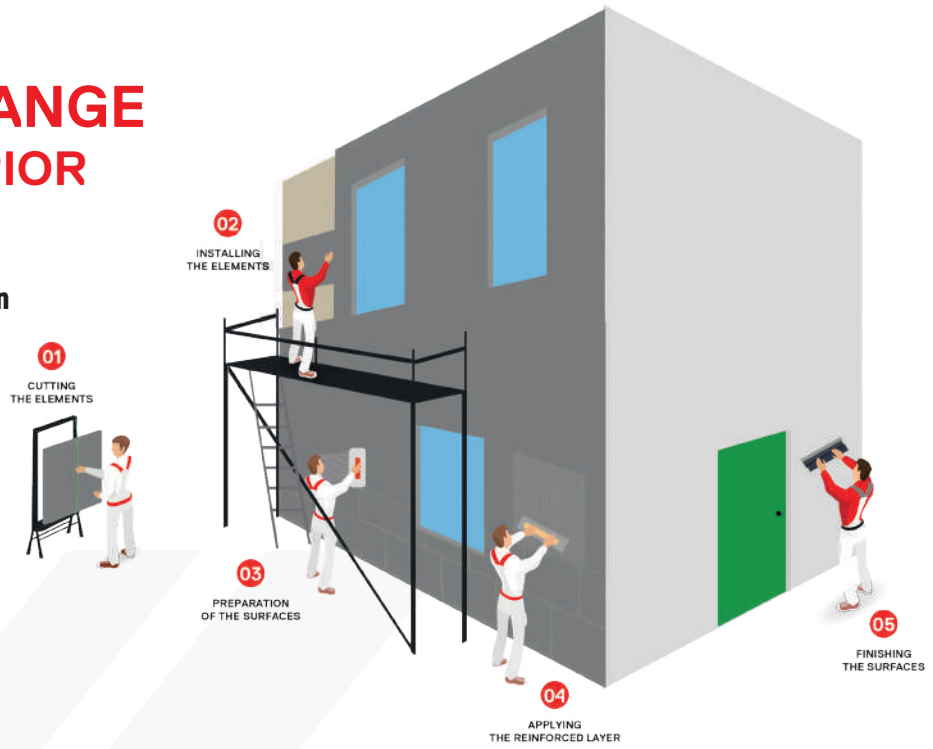

01

CUTTING THE ELEMENTS

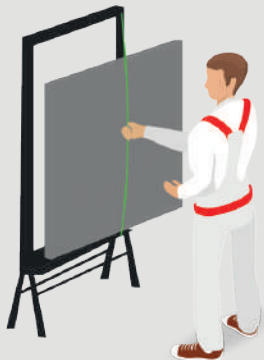

E.T.I.C.S. cutting table ParfaitCut®

- CUTTING TABLE FOR EPS AND XPS FOAMS, POLYSTYRENE
- HOT WIRE CUTTING : CLEAN AND NO PROJECTION
- SUPPLIED WITH SCAFFOLDING AND PEDAL OPTION
- TRANSPORT CASE WITH WHEELS

Specifications

- Max cutting depth: 330 mm
- Max cutting height: 330 mm
- Max cutting length: 1370 mm
- Ref 3113001: Spare hot wire



CODE	Quantity
3111000	1
E.T.I.C.S. CUTTING WIRE	
3113000	1



Thermal knife

FOR CLEAN CUTTING OF EXPANDED AND EXTRUDED POLYSTYRENE INSULATION (EPS AND XPS) - EFFORTLESS AND DUST-FREE THE BLADE REACHES 500°C IN A FEW SECONDS

Specifications

- Set includes :
 - 200 W thermal cutter
 - 2 blades: 150 and 200 mm
 - 1 angle guide - 115 cm cutting guide
 - 1 wire brush
 - 1 fixing key
- CE marked product

CODE	Quantity
3001000	1



Thermal knife & accessories

FOR CLEAN CUTTING OF EXPANDED AND EXTRUDED POLYSTYRENE INSULATION (EPS AND XPS) - EFFORTLESS AND DUST-FREE THE BLADE REACHES 500°C IN A FEW SECONDS

Specifications

- Set includes :
 - 200 W thermal cutter
 - 2 blades: 150 and 200 mm
 - 1 angle guide
 - 115 cm cutting guide
 - 1 wire brush
 - 2 folding blades for grooving
 - 1 cutting pliers - 1 bending pliers
 - 1 fixing key
- CE marked product

CODE	Quantity
3002000	1



Electric sabre saw

SAW FOR MINERAL INSULATING MATERIALS (ROCK WOOL, ETC.)

Specifications

- Comes in a case including:
- 300 mm blade
 - 18V Li-ion battery, 2000mAh
 - 65W/2300mA charger

CODE	
3173000	1
Sabre saw blade	
3174000	1



Insulation cutter

SCALLOPED EDGE FOR HARD MATERIALS - UNDULATED EDGE FOR SOFT MATERIALS

Specifications

- Double cutting stainless steel blade
- Handle fastened with rivets
- Weight : 160 g

Size	CODE	
28 cm	3073000	1
36 cm	3073036	1
48 cm	3073048	1



OP PROCESS®

02

INSTALLING
THE ELEMENTS



Half-moon notched trowel

FOR LAYING BIG FLOOR TILES AND ISOLATING PANELS

Specifications

- Stainless steel blade - 2 sides notched
- Semi-circular teeth - TKB M1
- Ergonomic bi-material handle, polypro mounting for rigidity/lightness
- Approximate consumption: 7.8 to 8.5kg/m²

CODE	
615000	1



Square notched trowel

Specifications

- Stainless steel blade - 2 sides notched - Square toothing - TKB C
- Consumption (approximate): TKB: C2 - 2.9 to 3.2 (Kg/m²) TKB: C4 - 3.3 to 4.2 (Kg/m²) TKB: C5 - 4.6 to 5 (Kg/m²)
- Ergonomic bi-material handle, polypro frame - Dimensions : 28 x 11 cm

Type	CODE	
TKB-C2	616006	1
TKB-C4	616008	1
TKB-C5	616010	1



03

PREPARATION
OF THE SURFACES



Float

FOR E.T.I.C.S. APPLICATIONS : SANDING POLYSTYRENE INSULATION BOARDS

Specifications

- One-piece polyurethane
- 15 to 20 mm thick
- For use with a self-adhesive abrasive pad Part No.2043028 Not included

Size	CODE	
28 x 50 cm	2042028	1
Sandpaper		
28 x 50 cm	2043028	1

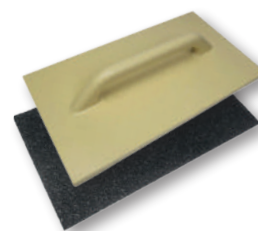

Abrasive float

SPECIALLY DESIGNED FOR E.T.I.C.S. APPLICATIONS:
SANDING OF POLYSTYRENE INSULATION BOARDS AND AE-
RATED CONCRETE
ECONOMICAL: AVOIDS THE USE OF CONSUMABLES

Specifications

- Galvanised plate
- Abrasive multi-holes
- Plastic handle

Size	CODE	
38 x 16 cm	2044038	1



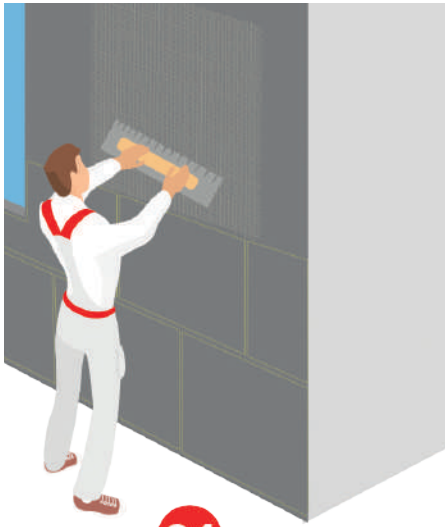

04

APPLYING THE REINFORCED LAYER

E.T.I.C.S. SET

NEW



SET DEDICATED TO EXTERNAL THERMAL INSULATION (E.T.I.C.S) WORK

Specifications

- 8-piece kit :
- 1 E.T.I.C.S. Notched trowel
- 110 cm stucco trowel
- 3 ParfaitLiss® Rigid (35, 60 and 100 cm)
- 1 Hard blade float
- 1 Slip-on float
- 1 PVC blade float

CODE

80623



1

E.T.I.C.S. ParfaitLiss® knife

FOR ADJUSTING THE THICKNESS OF THE COATING BEFORE INSTALLING THE REINFORCEMENT AS PART OF AN EXTERNAL WALL INSULATION (E.T.I.C.S.)

- For manual use or with ParfaitLiss® pole
- High performance Bi-Flex technology blade with PVC plate

Specifications

- Notched blade
- Tempered stainless steel
- Thickness 0.5 mm
- Trapezoidal teeth 6x4 - depth 7
- Consumption (for reference): 2.5 kg to 4.5 kg



STAINLESS STEEL

Size	CODE	Icon	
35 cm	7541035	2	NEW
60 cm	7541060	1	

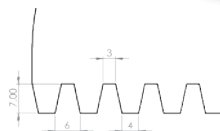

E.T.I.C.S. knife

NEW

FOR ADJUSTING THE PLASTER BEFORE LAYING THE WEFT STRAIGHT ANGLES

ERGONOMICALLY SHAPED HANDLE FOR A SECURE HOLD

Specifications

- Stainless steel serrated blade with aluminium reinforcement
- Riveted bi-material handle
- 6x4 trapezoidal teeth - depth 7
- Consumption (for reference): 2.5 kg to 4.5 kg



INOX

Size	CODE	Icon	
35 cm	1534035	1	
50 cm	1534050	1	
60 cm	1534060	1	
Wooden handle			
60 cm	1531060	50	

Decosol® 65 - TKB C

THE SOLUTION FOR INSTALLATION OF MATERIALS TO BE GLUED ON LARGE SURFACES.

Specifications

- 65 cm Stainless steel Blade
- Thickness: 0.5 mm
- Square teeth
- Blade changed by slide rail
- Approximate consumption:
- TKB C1 - 2.1 to 2.3 kg/m²
- TKB C2 - 2.9 to 3.2 kg/m²
- TKB C4 - 3.8 to 4.2 kg/m²
- TKB C5 - 4.6 to 5.0 kg/m²



STAINLESS STEEL

Size	CODE	Icon	
C1	6056504		
C2	6056506		
C4	6056508		
C5	6056510		

Notched trowel

NEW

TO ADJUST THE THICKNESS OF THE RENDERING BEFORE LAYING THE REINFORCEMENT FOR EXTERNAL THERMAL INSULATION (E.T.I.C.S.)

Specifications

- Notched blade - 6x4 trapezoidal teeth - Depth 7
- Tempered stainless steel, thickness 0.6 mm
- Natural beech wooden handle without lug
- Ambidextrous

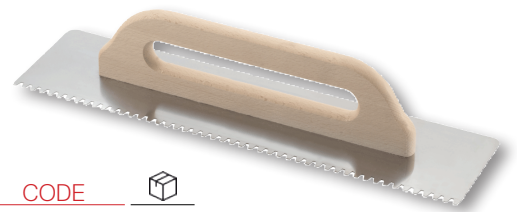

STAINLESS STEEL



Size	CODE	Icon	
48 x 12 cm	5542048	1	



05

FINISHING
THE SURFACES

ParfaitLiss® Rigid

NEW

SMOOTHING AND RAKING OF HEAVY PLASTER AND PLASTERWORK
NEW SOFT COMFORT NON-SLIP HANDLE
USE BY HAND OR WITH A PARFAITLISS® OP PROCESS® POLE



STAINLESS
STEEL



Specifications

- 0.5 mm tempered stainless steel blade
- High-performance Bi-Flex technology blade with PVC counter-blade
- Recyclable polypropylene and elastomer handle

Size	CODE	📦
25 cm	764025	2
35 cm	764035	2
45 cm	764045	2
60 cm	764060	2
80 cm	764080	1
100 cm	764100	1

E.T.I.C.S. Trowel

NEW

SPECIAL FOR RECESSES IN EXTERNAL THERMAL INSULATION COMPOSITE SYSTEM (E.T.I.C.S.)

Specifications

- 1 mm thick stainless steel
- Bi-material handle
- Lightweight aluminium frame



STAINLESS
STEEL

Size	CODE	📦
28 x 10 cm	5541028	1

Moulding trowel

ROLL OUT THE CANVAS WITHOUT TEARING IT OFF - COVER THE WEFT AND STRAIGHTEN THE SURFACES
HIGH RESISTANCE TO DEFORMATION AND WEAR

Specifications

- Tempered stainless steel blade
- Ergonomic composite handle
- Lightweight aluminium frame



STAINLESS
STEEL

Size	CODE	📦
300x80x0.6mm	4542030	1
480x100x1.0mm	4542048	1

Plastic trowel

NEW

IDEAL FOR SMOOTHING WITHOUT LEAVING TRACES WITH STUCO, FINE PLASTER, WAX AND FINISHING

Specifications

- Plastic blade and assembly
- Thickness 3 mm
- Extra light



Size	CODE	📦
28 x 13 cm	1673000	1

PVC blade trowel

NEW

FOR SMOOTHING AND SANDING INTERIOR AND EXTERIOR PLASTERS

Specifications

- PVC blade thickness 2 mm
- Soft composite handle
- Lightweight aluminium mounting
- Extra light



Size	CODE	📦
28 x 13.5 cm	612000	1



DécoLiss'® 52
 FaciLiss'® 53
 Joint knives 54 and 55
 Filling knives 56 at 59
 Scrapers 60 and 61
 Coating knives 62 at 65
 Stainless steel trowels 66
 Finishing trowels 67 and 68
 Decorating trowels 69 and 70
 Flooring and tiling 71 at 75
 Masonry 76 at 86

HAND TOOLS



Roller skimming Kit

APPLYING FILLER WITH THE 180 MM ROLL'ENDUIT® & SMOOTHING WITH DECOLISS® FLEXIBLE

Specifications

- 1 DecoLiss® Flexible (30 cm)
- 1 Roll'Enduit® 180 mm

CODE	
80474193	4



FaciLiss® Smoothing blade

FINISHING AND SMOOTHING OF JOINTING TAPE. SMOOTHING OF FINE AND LIGHT PLASTERS

Specifications

- 0.25 mm stainless steel blade
- Rounded edges
- High performance Bi-Flex technology blade with PVC plate

Size	CODE	
24 cm	3570024193	6
30 cm	3570030193	6
40 cm	3570040193	6
60 cm	3570060193	6



Roller skimming Kit XXL

APPLYING FILLER WITH THE 180 MM ROLL'ENDUIT® & SMOOTHING WITH FACILISS® FLEXIBLE

Specifications

- 1 Roll'Enduit® 180 mm
- 1 Handle
- 1 Extension pole 2x0,70 m
- 3 DecoLiss® Flexible (24 cm, 40 cm, 60 cm)

CODE	
80656193	4

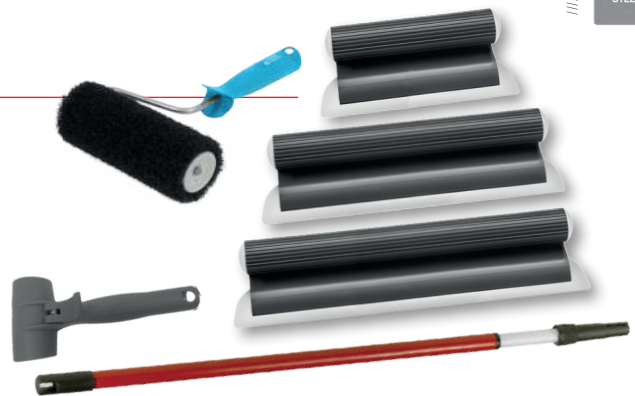

FaciLiss® stiff blade

FOR SMOOTHING FILLERS, HEAVY COATINGS, FIBRITE, ETC.

- Fixing and filling of plaster board jointing tape
- Applying of coatings: stucco, lime coating, waxed concrete, etc.
- Floor levelling: resins, coatings, etc.

Specifications

- 0.4 mm stainless steel blade
- Rounded edges
- High performance Bi-Flex technology blade with PVC plate

Size	CODE	
18 cm	3568018193	6
24 cm	3568024193	6
40 cm	3568040193	6

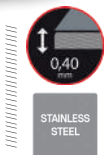
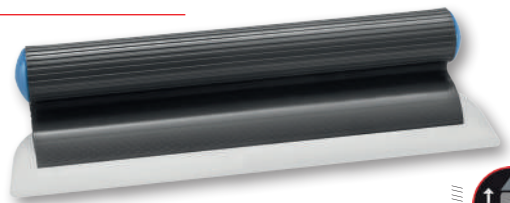

TO REACH CEILINGS

Use the FaciLiss® handle with the Extension pole.

FaciLiss® handle
56900013

Extension pole
1476

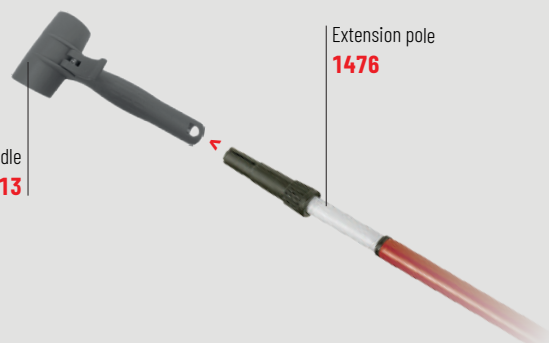

Joint knife with bit

TO COAT THE JOINTS OF PLASTERBOARD WITHOUT CHANGING A SCREW-ON TOOL

- Flexible blade - Long life
- Ergonomic and balanced shape

Specifications	Size	CODE	
- Tempered stainless steel blade	10 cm	2783010	5
- Bi-material handle	15 cm	2783015	5
- Through aluminium tip with bit			



STAINLESS STEEL

Pointing knife

PERFECT FOR CORNERS COATING

- Stiff blade

Specifications	Size	CODE	
- Polished tempered stainless steel blade	15 cm	2615015	5
- Ergonomic bi-material handle			
- Aluminium hammer cap			
- Registered design			



STAINLESS STEEL

Multipurpose scraper

6 TOOLS IN 1: SCRAPE, STRIP, FILL AND WIDEN CRACKS, CLEAN ROLLERS AND TAP

Specifications	Size	CODE	
- Tempered stainless steel blade	7 cm	2609000	5
- Shiny polished			
- Ergonomic bi-material handle			
- Aluminium hammer cap			
- Registered design			



STAINLESS STEEL

Multipurpose scraper

5 TOOLS IN 1: SCRAPE, STRIP, FILL AND WIDEN CRACKS AND CLEAN ROLLERS

Specifications	Size	CODE	
- Tempered polished stainless steel blade	7 cm	507000	5
- Polypropylene handle made from recycled and recyclable material			



STAINLESS STEEL

Multipurpose scraper

5 TOOLS IN 1 FOR THE PREPARING SUBSTRATES : SCRAPING, STRIPPING, FILLING, WIDENING CRACKS AND CLEANING ROLLERS

Specifications	Size	CODE	
- Tempered polished stainless steel blade	7 cm	2617000	5
- Ergonomic bi-material handle			
- Registered design			



STAINLESS STEEL

Corner cambered knife

PLASTERER'S KNIFE CURVED FOR EASY HAND CLEARANCE FROM THE SURFACE. POINTED FOR A PERFECT ANGLE.

Specifications	CODE	
- Tempered stainless steel blade	2589090	5
- Ergonomic bi-material handle		



STAINLESS STEEL



Filling knife

Specifications

- Varnished tempered steel blade
- Shiny polished
- PEFC wooden handle

Size	CODE	
2 cm	604002	5
3 cm	604003	5
4 cm	604004	5
5 cm	604005	5
6 cm	604006	5
7 cm	604007	5
8 cm	604008	5
9 cm	604009	5
10 cm	604010	5
12 cm	604012	5



Filling knife

Specifications

- Tempered stainless steel blade
- Shiny polished
- PEFC wooden handle

Size	CODE	
2 cm	510002	5
3 cm	510003	5
4 cm	510004	5
5 cm	510005	5
6 cm	510006	5
7 cm	510007	5
8 cm	510008	5
10 cm	510010	5



Spatula

Specifications

- Stainless steel blade
- Flexible
- Drop forged
- Brass ferrule
- Ebony-like handle

Size	CODE	
12 cm	440012	1
15 cm	440015	1
18 cm	440018	1
21 cm	440021	1
23 cm	440023	1
25 cm	440025	1
30 cm	440030	1



Spatula

Specifications

- Tempered stainless steel blade
- Flexible
- Sapelli handle
- Riveted 3 points

Size	CODE	
12 cm	442012	5
15 cm	442015	5
18 cm	442018	5
21 cm	442021	5
25 cm	442025	5
30 cm	442030	5





Rigid blade Scraper

FOR STRIPPING WORK

- Bevelled blade
- Wide bevel

Size	CODE	
6.5 cm	518000	5
Curved Blade		
	364000	1

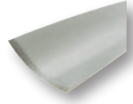

Specifications

- Tempered steel and varnished blade, sharpened
- Nickel-plated ferrule
- Natural wooden handle



Remover Scraper

TO SCRAPE AND STRIP

- Bevelled blade

Size	CODE	
7 cm	533000	5

Specifications

- Varnished, tempered steel blade
- Nickel-plated ferrule
- Ergonomic beech wooden handle



Builder Remover Scraper

SOLID BASE

- Wide bevel

Size	CODE	
7 cm	532007	5
10 cm	532010	5

Specifications

- Polished and varnished tempered steel blade
- Brass ferrule
- Beech wooden handle



Curved Painter remover Scraper

NEW

CURVED 20° FOR EASY HAND CLEARANCE FROM THE SURFACE

- Wide Bevel

Size	CODE	
8 cm	2631008	5

Specifications

- Varnished, tempered stainless steel blade 1.5 mm
- Rigid
- Bi-material handle, ergonomic shape
- Aluminium tip for striking
- **Registered design**



Bucket scoop

NEW

ROUNDED BLADE FOR FASTER PLASTER SETTING - FOR 17 KG BUCKET - CURVED FOR HAND RELEASE

Size	CODE	
19 cm	2599019	5
For 5 kg bucket		
10 cm	2594010	1

Specifications

- 0.5 mm stainless steel blade, Overmoulded
- Flexible blade to avoid scratching the bucket
- Ergonomic bi-material handle
- Aluminium hammer cap to balance weight



Rigid blade Scraper

LONG HANDLE

- Bevelled blade

CODE



365000

5

Specifications

- Varnished, tempered steel blade
- Nickel-plated ferrule
- 8" diameter shaft
- Beech wooden handle



Molding Scraper

3-SIDED SHARPENED BLADE WITH REUSABLE BLADE PROTECTION

Size

CODE



6 cm

360006

1

8 cm

360008

1

Specifications

- Varnished tempered steel blade
- Nickel-plated ferrule
- Beech wooden handle



Multipurpose molding Scraper

SHARPENED SHIELD-SHAPED BLADE WITH ROUNDED PART FOR PIPING WITH REUSABLE BLADE PROTECTION

CODE



1190000

1

Specifications

- Tempered steel blade, varnished, sharpened
- Nickel-plated ferrule
- Beech wooden handle



Double blade wooden scraper

SHARPENED AND REVERSIBLE BLADES

Size

CODE



4 cm

1176004

1

6 cm

1176006

1

Spare blades x 2

6 cm

3222006

5

Specifications

- Varnished, tempered steel blades
- Beech wooden handle



Glass Scraper

CLAMPING SYSTEM WITH KNOB

Size

CODE



4 cm

230000

5

Specifications

- Head with built-in blade 40 mm
- Includes: 1 blade Thickness 30/100
- Beech wooden handle

Spare blades x 50

4 cm

374000

1





Hacking knife

1 PART FORGED

- Blade ground on 2 sides (Length and width)

Specifications

- Blade 10 cm
- Varnished tempered steel blade

CODE	
527000	5
Notched hacking knife	
529000	5



Hacking knife

Specifications

- Blade 10 cm
- Tempered steel, varnished, sharpened
- Overmoulded ABS handle

CODE	
525000	5



Putty knife

FOR APPLYING SEALANTS TO WINDOWS, DOORS, ETC.

Specifications

- Varnished tempered steel blade
- Nickel-plated ferrule
- Beech wooden handle

CODE	
522000	5



Putty knife

FOR SMOOTHING PUTTY : ESSENTIAL FOR FINISHING CORNERS

- Curved shape for difficult to access areas

Specifications

- Varnished tempered steel blade
- Nickel-plated ferrule
- Beech wooden handle

CODE	
523000	5



Putty knife

FOR APPLYING PUTTY AROUND WINDOWS, DOORS, ETC.

Specifications

- Tempered steel blade
- **Solid forged base**
- Brass ferrule
- Polish sapelli wooden handle

CODE	
486000	5



Putty knife

IDEAL FOR MIRROR OR GLAZING WORK TO APPLY PUTTY AROUND A GLASS PANE TO ATTACH IT TO THE FRAME, WOOD, IRON OR EVEN ALUMINIUM

- Curved shape for difficult to reach areas

Specifications

- Tempered steel blade, bevelled
- **Solid Forged base**
- Brass ferrule
- Polished sapelli wooden handle

CODE	
487000	5



Dutch Putty knife

CURVED SHAPE FOR DIFFICULT AREAS

Specifications

- Tempered steel blade
- Varnished and polished
- Nickel-plated ferrule
- Natural wooden handle

CODE	
536000	5





Coating knife

Specifications

- Overmoulded Stainless steel blade
- Thickness : 0.46 mm
- 90° edges for corners
- Hard polypropylene handle
- **Registered design**

Size	CODE	
10 cm	546010	5
12 cm	546012	5
14 cm	546014	5
16 cm	546016	5
18 cm	546018	5
20 cm	546020	5
22 cm	546022	5
24 cm	546024	5
30 cm	546030	5

Size	CODE	
Round edges		
12 cm	546312	5
14 cm	546314	5
16 cm	546316	5
18 cm	546318	5
20 cm	546320	5
22 cm	546322	5
24 cm	546324	5



STAINLESS STEEL

Coating knife

Specifications

- Overmoulded tempered carbon steel
- Varnished - 90° edges for corners
- Hard polypropylene handle
- **Registered design**

Size	CODE	
10 cm	559010	5
12 cm	559012	5
14 cm	559014	5
16 cm	559016	5
18 cm	559018	5
20 cm	559020	5
22 cm	559022	5
24 cm	559024	5
30 cm	559030	5



STAINLESS STEEL

Drywaller case

Specifications

- Made up of :
- 4 Joint knives (8, 10, 12 and 15 cm)
 - 1 Multipurpose Scraper 6 in 1
 - 2 Coating knives (18 and 24 cm)
 - 1 Cutter 18 mm
 - 1 Compact measuring tape : 5 m

CODE	
80426	1



STAINLESS STEEL

Coating knife

FOR SPRAYED COATINGS ON CONCRETE AND OTHER SURFACES

- On formwork
- Straights edges

Specifications

- Stainless steel blade
- Varnished wooden handle
- Riveted 4 points

Size	CODE	
20 cm	549020	1
35 cm	549035	1
50 cm	549050	1
60 cm	549060	1



STAINLESS STEEL

Coating knife

ERGONOMICALLY SHAPE ENSURING A GOOD GRIP

- On formwork
- Straight edges

Specifications

- Stainless steel blade
- Aluminium reinforcement
- Riveted bi-material handle

Size	CODE	
35 cm	537035	1
50 cm	537050	1
60 cm	537060	1

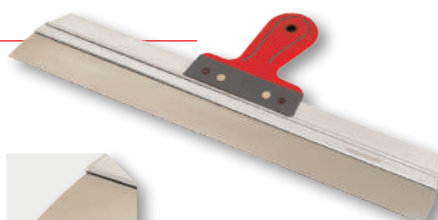

STAINLESS STEEL

Straights edges

Coating knife

ERGONOMICALLY SHAPED HANDLE FOR GOOD GRIP

- On formwork
- Round edges

Specifications

- Stainless steel blade
- Aluminium reinforcement
- Riveted bi-material handle

Size	CODE	
50 cm	534050	1
60 cm	534060	1

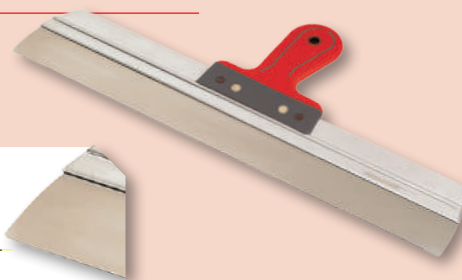

STAINLESS STEEL

Round edges

Coating knife

SPECIALLY DESIGNED TO COAT PLASTERBOARD AND FACILITATE FINISHING

- Straight edges

Specifications

- Stainless steel blade
- Aluminium reinforcement
- Natural beech wooden handle
- Riveted in 2 points

Size	CODE	
25 cm	1375025	1
30 cm	1375030	1
35 cm	1375035	1



STAINLESS STEEL

Coating knife

SPECIALLY DESIGNED TO COAT LARGE SURFACE

- Straight edges

Specifications

- Stainless steel blade
- Aluminium reinforcement
- Natural beech wooden handle
- Riveted in 2 points

Size	CODE	
60 cm	531060	1



STAINLESS STEEL



Float Trowel

TO APPLY PLASTER AND SMOOTH COATING
SEMI-RIGID BLADE MAKES IT MORE
SUITABLE FOR SMOOTHING A SCREED

Size	CODE	
50 x 14 cm	618000	1

Specifications

- Stainless steel blade
- Thickness 0.7 mm
- Beech wooden handle



STAINLESS
STEEL

Float Trowel

SWISS HANDLE FLOAT WITH ENDS : IDEAL
FOR PLASTER SMOOTHING WORK
2-HAND WORK

Size	CODE	
50 x 14 cm	631000	1

Specifications

- Stainless steel blade
- Thickness 0.7 mm
- Beech wooden handle

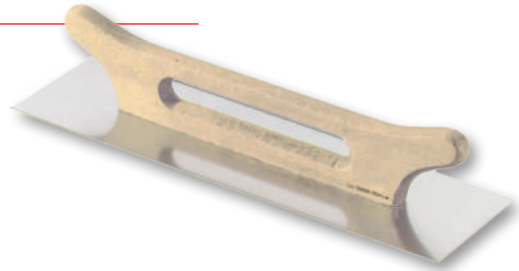

STAINLESS
STEEL

Coating knife

2 BLADES SCREWED
ADJUSTABLE FLEXIBILITY

Specifications

- Very flexible tempered steel blade
- Beech wooden handle

Size	CODE	
15 cm	901015	5
20 cm	901020	5
30 cm	901030	5
Stainless Steel Blade		
15 cm	902015	5
20 cm	902020	5
30 cm	902030	5



Flexible scrapers

FLEXIBLE BLADE FOR COATING AND
DECORATING

Specifications

- Tempered steel blade
- Straight edges

Size	CODE	
3 cm	422003	1
6 cm	422006	1
8 cm	422008	1
10 cm	422010	1
12 cm	422012	1
Set of Flexibles scrapers : 5, 8, 10 and 12 cm		
414000		1



STAINLESS
STEEL

Flexible scrapers

EXTRA SOFT BLADES

Specifications

- Stainless steel blade
- Rounded edges

Size	CODE	
6 cm	1474006	1
8 cm	1474008	1
10 cm	1474010	1
12 cm	1474012	1
Set of Flexibles scrapers : 6, 8, 10 and 12 cm		
1473300		1

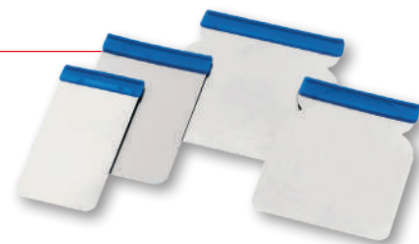

STAINLESS
STEEL



Double blade Finishing trowel

FINISH PLASTERBOARD TAPES AND SURFACES

- Flat smoothing, with no removal of material
- Round edges, no visible rivets : smoothing without burrs

Size	CODE	
30 x 11 cm	1725030	1
35 x 11 cm	1725035	1
40 x 11 cm	1725040	1
45 x 11 cm	1725045	1

Specifications

- Tempered stainless steel blade
- **Thickness 0.3 mm**
- Bi- material polycarbonate soft handle
- Bi-flex double blade technology
- Patented



TEMPERED STAINLESS STEEL

Bi-Flex Finishing Trowel

RECOMMENDED TO FLATTEN DOWN JOINT

- Bi-Flex technology Gradually progressive round edges and corners to leave no mark
- Concave base to compensate for plaster shrinkage
- Slim and nifty - 40% lighter

Size	CODE	
30 x 11 cm	1718028	1
35 x 11 cm	1718035	1

Specifications

- Tempered stainless steel blade
- **Thickness 0.4 mm**
- Double row of rivets
- Rubber handle for comfort, polycarbonate frame for rigidity and lightness
- Patented



TEMPERED STAINLESS STEEL

Bi-Flex Finishing Trowel

BI-FLEX TECHNOLOGY

- Gradual rounded edges and angles to leave no marks
- Ultra lightweight

Size	CODE	
30 x 11 cm	1719030	1
35 x 11 cm	1719035	1

Specifications

- Tempered stainless steel blade
- **Thickness 0.4 mm**
- Wide concave base
- Double row of rivets
- Ergonomic bi-material handle, polypropylene frame for rigidity and lightness balance
- Patented



TEMPERED STAINLESS STEEL

Finishing trowel

NARROW AND LONG BLADE

Specifications

- Stainless steel blade
- **Thickness 0.5 mm**
- Rubber material handle for comfort, polycarbonate frame for rigidity/ lightness balance
- Patented

Size	CODE	
35 X 11 cm	1713035	1
Large model		
28 x 12.5 cm	1714028	1
35 x 12.5 cm	1714035	1



STAINLESS STEEL

Double blade Finishing trowel

FLAT SMOOTHING, WITH NO REMOVAL OF MATERIAL

- Round edges
- No visible rivets : smoothing without burrs

Size	CODE	
30 X 11 cm	1726030	1
35 X 11 cm	1726035	1
40 X 11 cm	1726040	1
45 X 11 cm	1726045	1

Specifications

- Tempered stainless steel blade
- **Thickness 0.3 mm**
- Ergonomic composite handle
- Lightweight aluminium frame
- Bi-flex double blade technology



The BI-FLEX effect is the combination of hardness and flexibility of the blades, enabling even smoothing across the entire surface.

NO VISIBLE RIVETS



TEMPERED STAINLESS STEEL

Finishing trowel

FOR PRESSING AND POLISHING FINE COATINGS AND STUCCO

- Narrow and long blade

Size	CODE	
35 x 10 cm	2357000	1

Specifications

- Stainless steel blade
- **Thickness 0.6 mm**
- Ergonomic composite handle
- Lightweight aluminium frame
- Registered design



STAINLESS STEEL

Finishing trowel

NARROW AND LONG BLADE

- Bevelled blade for no marks

Size	CODE	
35 x 10 cm	2356000	1

Specifications

- Stainless steel blade
- **Thickness 0.6 mm**
- Ergonomic composite handle
- Lightweight aluminium frame
- Registered design



STAINLESS STEEL



Deco flexible trowel

- Gradual rounded edges and angles
- Flexible
- Trapezoidal shape

Specifications

- Polished tempered stainless steel blade
- **Thickness 0.4 mm**
- Rubber resin handle / Polycarbonate frame
- Double row of rivets
- Available with polypropylene frame : Code 1715*

Size	CODE	
20 x 8 cm	1716008	1
24 x 11 cm	1716411	1
28 x 12 cm	1716812	1



*Code 1715

TEMPERED STAINLESS STEEL

Deco flexible trowel

- Extra flexible
- 1 triangular side

Specifications

- Tempered stainless steel blade
- **Thickness 0.3 mm**
- Bi-flex double blade technology
- Rubber resin handle / Polycarbonate frame

Size	CODE	
21 x 6/6.5 cm	1727021	1



TEMPERED STAINLESS STEEL

Deco flexible trowel

- Extra flexible
- 1 rounded side

Specifications

- Tempered stainless steel blade
- **Thickness 0.3 mm**
- Bi-flex double blade technology
- Rubber resin handle / Polycarbonate frame

Size	CODE	
22 x 7 cm	1728022	1



TEMPERED STAINLESS STEEL

Deco flexible trowel

- Extra flexible
- Trapezoidal blade

Specifications

- Tempered stainless steel blade
- **Thickness 0.3 mm**
- Bi-flex double blade technology
- Rubber resin handle / Polycarbonate frame

Size	CODE	
27 x 7.5/8 cm	1734027	1



TEMPERED STAINLESS STEEL

Deco flexible trowel

- Extra flexible
- 2 rounded sides
- Also to seal the porosity after application of coloured hardeners

Specifications

- Tempered stainless steel blade
- **Thickness 0.3 mm**
- Bi-flex double blade technology
- Rubber resin handle / Polycarbonate frame

Size	CODE	
36 x 8 cm	1724036	1



TEMPERED STAINLESS STEEL

Round trowel

FOR AGGRESSIVE DECORATIVE COATINGS, STUCO AND GREASY COATINGS

- For application without black or oxidation marks
- Rounded angles - Bevelled on 4 sides

Specifications

- Semi-rigid plastic blade
- **Thickness 2 mm**
- Bi-material polycarbonate/rubber resin handle



Special decorative effect trowel

PLASTIC FLOAT TROWEL SPECIAL FOR STUCO, GREASY COATINGS

Specifications

- Flexible blade
- 1 triangular side

Size	CODE	
24 x 9.5 cm	1677000	1





DécoSol®

TILING



OP Process®
Multipurpose pole
1766 + 3348000
or **1348**

DecoLiss®
handle
577000

DecoSol®
6053
6056

STAINLESS
STEEL

DecoSol®

SOLUTION FOR TILING

- Square notch
- Manual use or with the handle code 577000 to choose the working angle

Specifications

- Stainless steel
 - **Thickness: 0.5 mm**
 - Interchangeable blades
 - Blade changed by sliding
 - Approximate consumption:
- TKB C1 - 2.1 to 2.3 kg/m²
TKB C2 - 2.9 to 3.2 kg/m²
TKB C4 - 3.8 to 4.2 kg/m²
TKB C5 - 4.6 to 5.0 kg/m²

✓ Available in : 12, 18, 50, 90 and 110 cm

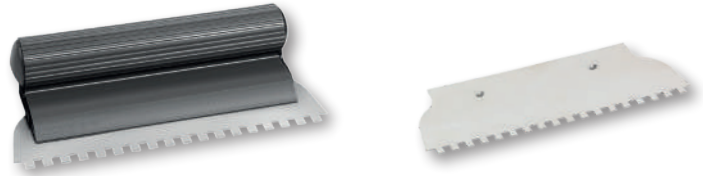

SIZE	TYPE	DIAGRAM	DECOSOL® CODE		BLADE CODE	
30 cm 65 cm	TKB - C1	 4x4 mm	6053004 6056504	1	6083004 6086504	5
30 cm 65 cm	TKB - C2	 6x6 mm	6053006 6056506	1	6083006 6086506	5
30 cm 65 cm	TKB - C4	 8x8 mm	6056008 6056508	1	6083008 6086508	5
30 cm 65 cm	TKB - C5	 10x10 mm	6056010 6056510	1	6083010 6086510	5
SET 12, 18 & 30 cm	TKB - C2	 6x6 mm	80806	1		

DecoLiss® handle

HANDLE FOR DECOSOL® ENABLING YOU TO CHOOSE YOUR WORKING ANGLE

Specifications

- Male conical head with fixing pins
- Cam locking system : Fast and efficient

CODE
577000 1



Multipurpose pole

- Adjustable upper head
- Screw system in the centre

Specifications

- 2 ultra-light ribbed aluminium sections
- Fixing system with handle centring device
- Cam locking system

Size	CODE	
2 x 0.70 m	1348070	4
2 x 1.00 m	1348100	4
2 x 1.50 m	1348150	4



Half-moon notched trowel

RECOMMENDED FOR LAYING BIG FLOOR TILES AND ISOLATING PANELS

Specifications

- Stainless steel blade
- 2 sides notched
- Ergonomic bi-material handle
- Polypro frame
- Dimensions : 28 x 11 cm

A

Type	CODE	
TKB-M1	615000	1



STAINLESS STEEL

Square notched trowel

RECOMMENDED FOR LAYING FLOOR

Specifications

- Stainless steel blade
- 2 sides notched
- Ergonomic bi-material handle
- Polypro frame
- Dimensions : 28 x 11 cm

B

Type	CODE	
TKB-C2	616006	1
TKB-C4	616008	1
TKB-C5	616010	1



STAINLESS STEEL

Square notched trowel

RECOMMENDED FOR LAYING FLOORS

Specifications

- Stainless steel blade
- Thickness : 0,6 mm
- 2 sides notched
- Wooden handle
- Dimensions : 50 x 14 cm

B

Type	CODE	
TKB-C2	619006	1
TKB-C4	619008	1
TKB-C5	619010	1

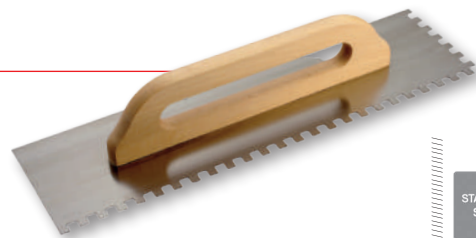

STAINLESS STEEL

TROWEL	NOTCH	BLADE	DIAGRAM	TYPE	RECOMMENDATION	CONSUMPTION (FOR INFORMATION)
A 615000	- Half moon - 20 x 10 x 15 mm	Stainless steel		TKB - M1	For laying big wall tiles, insulation panels	7,8 to 8,5 kg/m ²
B 616006	- Square - Normal - 6 x 6 mm	Stainless steel		TKB - C2	For laying floor tiles, Tiles < 300 cm ² (eg: 10x30) or < 900 cm ² (eg : 30 x 30 cm) with double buttering	2,9 to 3,2 kg/m ²
B 616008	- Square - Medium - 8 x 8 mm	Stainless steel		TKB - C4	For laying floor tiles, Tiles > 900 cm ² (eg : 60 x 60 cm) with double buttering	3,8 to 4,2 kg/m ²
B 616010	- Square - Big - 10 x 10 mm	Stainless steel		TKB - C5	For laying heavy materials and tiles > 900 cm ² (eg : 60 x 60 cm)	4,6 to 5 kg/m ²



Square adhesive spreader

FOR THE LAYING FLOOR TILES

Specifications **A**

- Varnished tempered steel blade
- Square notch
- PEFC beech wooden handle

SQUARE - FINE			SQUARE - NORMAL			SQUARE - BIG			SQUARE - VERY BIG		
Size	CODE		Size	CODE		Size	CODE		Size	CODE	
12 cm	560012	5	12 cm	561312	5	20 cm	561220	5	20 cm	561120	5
20 cm	560020	5	20 cm	561320	5	30 cm	561230	5			
			30 cm	561330	5						



Rectangular adhesive spreader

FOR LAYING TECHNICAL FLOOR COVERINGS

Specifications **B**

- Varnished tempered steel blade
- Square notch
- PEFC beech wooden handle

RECTANGULAR - FINE			RECTANGULAR - MEDIUM			RECTANGULAR - NORMAL			RECTANGULAR - NORMAL		
Size	CODE		Size	CODE		Size	CODE		Size	CODE	
20 cm	560320	5	20 cm	560220	5	12 cm	560112	5	20 cm	560120	5
			30 cm	560230	5				30 cm	560130	5



Curved floor adhesive spreader

RECOMMENDED FOR LAYING FLOOR TILES
CAMBERED BLADE FOR COMFORT OF USE

Specifications **C**

- Varnished tempered steel blade
- Square notch
- PEFC beech wooden handle

Size	CODE	
24 cm	554000	5



	BLADES	NOTCH	BLADE	DIAGRAM	TYPE	RECOMMENDATION	CONSUMPTION (FOR INFORMATION)
A	5600	- Square - Thin - 4,5 x 4,5 x 4,5 mm	Varnished steel		TKB - C1	For laying floor tiles	2,1 to 2,3 kg/m ²
A	5613	- Square - Normal - 6 x 6 mm	Varnished steel		TKB - C2	For laying floor tiles, Tiles <300 cm ² (eg: 10x30) or <900 cm ² (eg: 30x30) with double buttering.	2,9 to 3,2 kg/m ²
A	5612	- Square - Big - 10 x 10 mm	Varnished steel		TKB - C5	For laying heavy materials and tiles >900 cm ² (eg: 60x60)	4,6 to 5 kg/m ²
A	5611	- Square - Very big - 15 x 15 mm	Varnished steel		TKB - C	For laying very hard materials Adhesive mortar	7 to 7,7 kg/m ²
B	5601	- Rectangular - Normal - 4,5 x 2,5 x 2,5 mm	Varnished steel		TKB - R	For laying heavy floor coverings and small tiles.	450 to 550 g/m ²
B	5603	- Rectangular - Thin - 4 x 2,5 x 1 mm	Varnished steel		TKB - R	For laying technical floor coverings.	150 to 200 g/m ²
B	5602	- Rectangular - Medium - 4 x 2,5 x 1,5 mm	Varnished steel		TKB - R1	For laying LVT2, homogeneous PVC, VSM floor coverings, ect.	250 to 300 g/m ²
C	554	- Square - Normal - 6 x 6 mm	Varnished steel		TKB - C2	For laying floor tiles. Tiles <300 cm ² (eg: 30x30) or <900 cm ² (eg: 30x30) with double buttering.	2,9 to 3,2 kg/m ²

DécoSol®

FLOORING



DecoLiss®
handle
577000

OP Process®
Multipurpose pole
1766 + 3348000
or **1348**

DecoSol®
6050
6080

DecoSol®

- Can be used with DécoLiss® Handle (Code 577000) and pole

Specifications

- Stainless steel blade
- **Thickness : 0.5 mm**
- Interchangeable blades
- Pointed notch

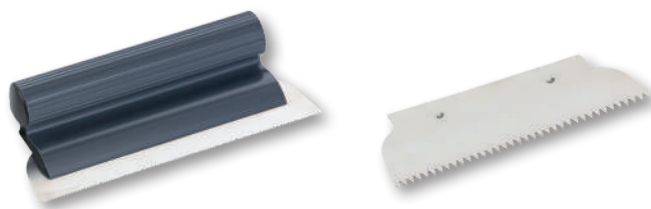

SIZE	TYPE	DIAGRAM	DECOSOL® CODE		BLADE CODE							
12 cm 18 cm 30 cm 50 cm SET	TKB - A1 2,9 to 3,2 kg/m ²	<p>0,5 1,5 0,5 x 1,5 mm</p> <p>FOR INSTALLING PVC, RUBBER, SMOOTH FOAM, AND HOMOGENEOUS PVC FLOOR COVERINGS.</p>	60510012 60510018 60510030 60510050 80810	1	60810012 60810018 60810030 60810050	5						
12 cm 18 cm 30 cm 50 cm SET			TKB - A2 2,9 to 3,2 kg/m ²	<p>1,4 1,7 1,4 x 1,7 mm</p> <p>FOR INSTALLING PVC, RUBBER, SMOOTH FOAM, AND HOMOGENEOUS PVC FLOOR COVERINGS.</p>	60511012 60511018 60511030 60511050 80811	1	60811012 60811018 60811030 60811050	5				
12 cm 18 cm 30 cm 50 cm SET					TKB - B11 2,9 to 3,2 kg/m ²	<p>7,9 6,1 7,9 x 6,1 mm</p> <p>FOR BIG BLADE : FOR FLOOR INSTALLATION OF ENGINEERED WOOD FLOORING, LAMINATE FLOORING...</p>	60513012 60513018 60513030 60513050 80813	1	60813012 60813018 60813030 60813050	5		
30 cm 65 cm							TKB - S3 250 to 350 g/m ²	<p>1,5 2,8 2,8 x 1,5 mm</p> <p>FOR SELF SMOOTHING, RESIN BASED COVERING FOR LAYING LIGHT WALL COVERINGS</p>	6050030 6050065	1	6080030 6080065	5

DECOSOL® SET

12, 18, 30 cm
with 3 spare blades

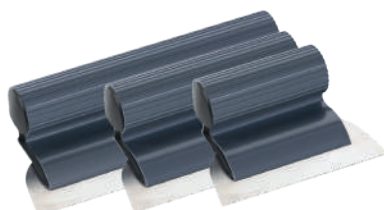



Pointed notched trowel

RECOMMENDED FOR HEAVY WALL COVERINGS

Type	CODE	
TKB-S	1866000	1

A

Specifications

- Stainless steel blade
- 2 sides notched
- Ergonomic bi-material handle
- Polypro frame
- Dimensions : 28 x 11 cm



Medium trapezoidal adhesive spreader

FOR LAYING PVC, RUBBER, SMOOTH FOAM, HOMOGENEOUS PVC AND MINERAL TILE FLOOR COVERINGS

Size	CODE	
20 cm	562220	5
30 cm	562230	5

B

Specifications

- Varnished tempered steel blade
- Trapezoidal notch
- PEFC beech wooden handle



Pointed adhesive spreader

Specifications

- Varnished tempered steel blade
- Trapezoidal notch
- PEFC beech wooden handle



C

Stainless steel adhesive spreader

FOR LAYING PVC, RUBBER, SMOOTH FOAM, HOMOGENEOUS PVC AND MINERAL TILE FLOOR COVERINGS

Size	CODE	
20 cm	563020	5
30 cm	563030	5

D

Specifications

- Stainless steel blade
- Trapezoidal notch
- PEFC beech wooden handle



POINTED - VERY FINE		
Size	CODE	
20 cm	562420	5
30 cm	562430	5

POINTED - FINE		
Size	CODE	
8 cm	562308	5
12 cm	562312	5
20 cm	562320	5
30 cm	562330	5

POINTED - NORMAL		
Size	CODE	
12 cm	562112	5
20 cm	562120	5
30 cm	562130	5

BLADES	NOTCH	BLADE	DIAGRAM	TYPE	RECOMMENDATION	(FOR INFORMATION)
A 1866000	- Pointed - Normal - 4 x 2,5 mm	Stainless steel		TKB - S	For heavy wall coverings	700 to 800 g/m ²
B 562220 562230	- Trapezoidal - Medium - 2 x 2 x 1,5 mm	Varnished steel		TKB - A2	For PVC, rubber, smooth foam, homogeneous PVC coverings	250 to 300 g/m ²
C 5624	- Pointed - Very fine - 2 x 1 mm	Varnished steel		TKB - S	For laying light wall thin cork covering	350 to 400 g/m ²
C 562308 562312 562320 562330	- Pointed - Fine - 2,8 x 1,5 mm	Varnished steel		TKB - S3	For medium thickness wall coverings such as PVC, cork, insulation, etc.	550 to 600 g/m ²
C 562112 562120 562130	- Pointed - Normal - 4 x 2,5 mm	Varnished steel		TKB - S	For heavy wall coverings such as cladding, polystyrene insulation	700 to 800 g/m ²
D 563020 563030	- Trapezoidal - Medium - 2 x 2 x 1,5 mm	Stainless steel		TKB - A2	For PVC, rubber, smooth foam, homogeneous PVC coverings	250 to 300 g/m ²

Scraper float

SPECIALLY FOR RENDERING AND HARD COATINGS

Specifications

- Press-drawn sheet metal
- Dimensions: 142 x 254 mm
- Ergonomic handle
- Ambidextrous
- Mounted with 4 nuts
- 2 lengths / 2 densities of spikes



Size	CODE	
480 x 8 mm	634008	2
260 x 15 mm	634015	2

Scratch float Spare blade

Specifications

- Press-drawn sheet metal
- Dimensions: 142 x 254 mm
- 2 lengths / 2 densities of spikes

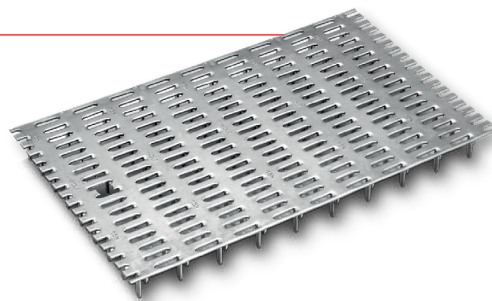

Size	CODE	
480 x 8 mm spikes	2634008	6

Dutty floor/Tile roofing scraper

WELDED BLADE SCRAPER

- To scrape formwork boards, floors before laying carpet
- Bevelled blade

Specifications

- Tempered polished steel blade
- **Thickness : 1.2 mm**
- Stainless steel back
- Fits on handle Diameter 40 mm (Code 1491000, not supplied)

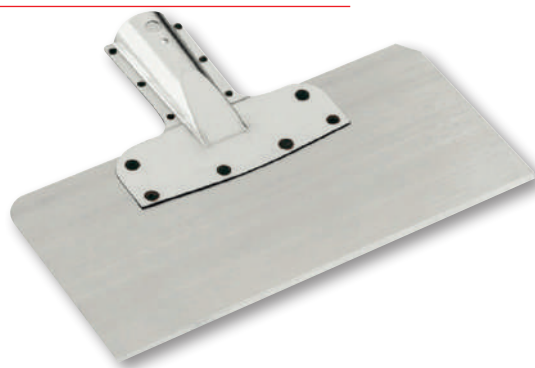

Size	CODE	
150 mm	879150	1
300 mm	879300	1



Forged remover scraper

ONE PIECE FORGED STEEL
WIDE BEVEL

Specifications

- Ergonomic shaped overmoulded handle with shock absorbing sleeve
- Removable suspension hook

Size	CODE	
6.5 cm	535000	1



Builder Remover Scraper

SOLID BASE
WIDE BEVEL

Specifications

- Polished and varnished tempered steel blade
- Brass ferrule
- PEFC Beech wooden handle

Size	CODE	
7 cm	532007	5
10 cm	532010	5



Builder Remover Scraper

FOR SCRAPING AND STRIPPING

- Through blade
- Wide bevel

Specifications

- Polished and varnished tempered steel blade
- Nickel-plated ferrule
- PEFC beech wooden handle

Size	CODE	
7 cm	1686000	5
10 cm	1686010	5



MANUFACTURER SINCE 1920





Finishing trowel

SPANISH FRAME - RECTANGULAR

Size	CODE	
30 x 14 cm	2278000	1

Specifications

- Tempered stainless steel blade
- **Thickness 0.6 mm**
- PEFC beech wooden handle

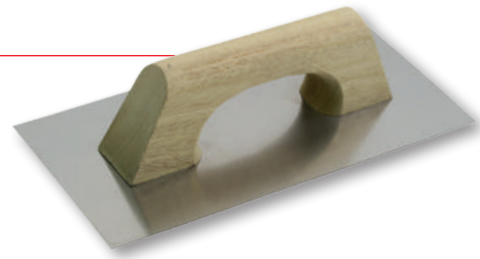

STAINLESS STEEL

Float Trowel

ROUND FRONT SIDE

Size	CODE	
29 cm	910029	1
Bi-material handle		
29 cm*	910129	1

Specifications

- Tempered steel blade
- **Thickness 1 mm**
- Lightweight aluminium frame
- PEFC beech wooden handle
- * Available in composite handle



Concrete float trowel

FLEMISH SHAPE, LANCET FRONT SIDE

Size	CODE	
45 cm	633045	1
60 cm	633060	1

Specifications

- Tempered steel blade
- Lightweight aluminium frame
- PEFC beech wooden handle



Flemish steel screed trowel

FLEMISH SHAPE, LANCET FRONT SIDE

Size	CODE	
35 cm	632035	1
45 cm	632045	1
60 cm	632060	1

Specifications

- Tempered steel blade
- Lightweight aluminium frame
- Ergonomic composite handle



Concrete float trowel

FLEMISH SHAPE
LIGHTWEIGHT

Size	CODE	
35 cm	1867035	1
45 cm	1867045	1
60 cm	1867060	1

Specifications

- Tempered stainless steel blade
- Lancet front side
- Lightweight aluminium frame
- Ergonomic composite handle



STAINLESS STEEL



Tuck pointing Trowel

FLEXIBLE BLADE - FLAT

Specifications

- Steel blade
- PEFC beech wooden handle
- Nickel-plated steel ferrule

Size	CODE	
8 mm	659008	1
10 mm	659010	1
12 mm	659012	1



Tuck pointing Trowel

RIGID BLADE - CURVED SHAPE

Specifications

- Steel blade
- PEFC beech wooden handle
- Nickel-plated steel ferrule

Size	CODE	
10 mm	699010	1



Round Trowel

WITH INDEX FINGER PROTECTION AND UNBREAKABLE STRIKING TIP

Specifications

- Varnished tempered steel blade
- Composite handle
- **Registered design**

Size	CODE	
160 mm	2100160	3
180 mm	2100180	3
200 mm	2100200	3
220 mm	2100220	3
240 mm	2100240	3



Square Trowel

WITH INDEX FINGER PROTECTION AND UNBREAKABLE STRIKING TIP

Specifications

- Varnished tempered steel blade
- Composite handle
- **Registered design**

Size	CODE	
160 mm	2101160	3
180 mm	2101180	3
200 mm	2101200	3
220 mm	2101220	3



Cat Tongue Trowel

UNBREAKABLE STRIKING TIP

Specifications

- Varnished tempered steel blade
- Composite handle
- **Registered design**

Size	CODE	
140 mm	2102140	3
160 mm	2102160	3
180 mm	2102180	3





Greek pattern brick trowel

Specifications	Size	CODE		Size	CODE	
<ul style="list-style-type: none"> - Polished and varnished tempered steel blade - PEFC beech wooden handle - Nickel-plated ferrule and cap * Model with composite handle - Registered design 	127 mm / 5"	649127	1	Bi-material handle*		
	152 mm / 6"	649152	1	* 152 mm / 6"	649106	1
	165 mm / 6.5"	649165	1	* 178 mm / 7"	649107	1
	178 mm / 7"	649178	1	* 200 mm / 8"	649108	1
	190 mm / 7.5"	649190	1	* 230 mm / 9"	649109	1
	200 mm / 8"	649200	1			
	216 mm / 8.5"	649216	1			
	230 mm / 9"	649230	1			



Crete pattern Trowel

Specifications	Size	CODE		Size	CODE	
<ul style="list-style-type: none"> - Polished and varnished tempered steel blade - PEFC beech wooden handle - Nickel-plated ferrule and cap * Model with composite handle - Registered design 	200 mm	620200	1	Bi-material handle*		
	220 mm	620220	1	* 200 mm	620120	1
	240 mm	620240	1	* 220 mm	620122	1
	260 mm	620260	1	* 240 mm	620124	1
	280 mm	620280	1	* 260 mm	620126	1



Greek pointed tip trowel

Specifications	Size	CODE	
<ul style="list-style-type: none"> - Polished and varnished tempered steel blade - PEFC beech wooden handle - Nickel-plated ferrule and cap * Model with composite handle - Registered design 	120 mm	646120	1
	140 mm	646140	1
	Bi-material handle*		
	* 120 mm	646112	1
	* 140 mm	646114	1



Greek trowel

Specifications	Size	CODE		Size	CODE	
<ul style="list-style-type: none"> - Polished and varnished hardened steel blade - PEFC beech wooden handle, glued- Nickel-plated ferrule and cap * Model with bi-material handle 	180 mm	647180	1	Bi-material handle*		
	200 mm	647200	1	* 180 mm	647118	1
	220 mm	647220	1	* 200 mm	647120	1
	240 mm	647240	1	* 220 mm	647122	1
	260 mm	647260	1	* 240 mm	647124	1
	280 mm	647280	1	* 260 mm	647126	1
				* 280 mm	647128	1



North of Greece pattern Trowel

Specifications	Size	CODE	
<ul style="list-style-type: none"> - Polished and varnished tempered steel blade - Composite handle with index fingerguard - Nickel-plated ferrule and cap - Registered design * Available : PEFC beech wooden handle 	* 220 mm	2078122	1
	* 240 mm	2078124	1
	* 260 mm	2078126	1





Antwerp pattern Trowel

THICK AND RIGID BLADE
ROUND TIP

Size	CODE	
180 mm	190311835	1
200 mm	1903100	1
Wooden handle*		
* 180 mm	1903180	1
* 200 mm	1903000	1

Specifications

- Varnished tempered steel blade
- Curved Neck
- Model with bi-material handle
- **Registered design**
- * Model with wooden handle



Brussels pattern Trowel

POINTED TIP BLADE
THICK AND RIGID

Size	CODE	
180 mm	190211835	1
Wooden handle*		
* 180 mm	1902180	1

Specifications

- Varnished tempered steel blade
- Curved Neck
- Model with bi-material handle
- **Registered design**
- * Model with wooden handle



Tile Setting Trowel

POINTED TIP BLADE
FLEXIBLE

Size	CODE	
170 mm	190410035	1
Wooden handle*		
* 170 mm	1904000	1

Specifications

- Varnished tempered steel blade
- Curved Neck
- Model with bi-material handle
- **Registered design**
- * Model with wooden handle



Round tip Trowel

FLEXIBLE

Size	CODE	
120 mm	190711235	1
140 mm	190711435	1
160 mm	190711635	1
180 mm	190711835	1
Wooden handle*		
* 120 mm	1907120	1
* 140 mm	1907140	1
* 160 mm	1907160	1
* 180 mm	1907180	1
* 200 mm	1907200	1

Specifications

- Varnished tempered steel blade
- Curved Neck
- Model with bi-material handle
- **Registered design**
- * Model with wooden handle





Rollers for smooth surfaces 92 at 98
 Rollers for even surfaces 99 at 104
 Rollers for uneven surfaces 105 at 107
 AquaLiss'6 96
 AquaLiss'9 96
 AquaLiss'13 102 and 110
 MicroLiss'6 97
 MicroLiss'10 103
 MicroLiss'HD 12 103 and 110
 MicroLiss'14 & 18 104
 PolyGold 12 100
 TechniFibre'PA 12 101
 TechniFibre'PA 18 106
 Frames 111 at 113
 Poles 114 and 115
 Accessories 116 at 120
 Brushes 121 at 136

ROLLERS & BRUSHES

GREAT TECHNICAL PERFORMANCES

CLIP

The folded bevelled edge and thermo fusions assembly eliminates any risk of the cover fabric coming loose or drips on the edges of the roller cover.

High quality fabric
For faster application.
Brushed finish.

Guiding cone
To help centre it
on the core.

Study composite ring
High adhesion and
memory retention.

Retaining clips

Shape of the roller frame
To reduce rubbing and helps
keep the cover clean.

Shaped cage to position
the thumb, easy fitting
on the bucket edge.

**Concave high-resistance
polypropylene flange**
To avoid marks.

Fabrics folded onto tube
For high tear resistance
and to avoid ripple marks
left by the edges.

Dual-material technical grip
More ergonomic.

Folded bevelled edges
To avoid excess paint
on the edges of the roller.

DIFFERENT KIND OF FABRICS

Our experience and know-how allows us to develop fabrics that align with the evolution of paints offered in the professional network.

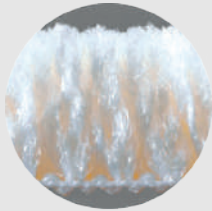

Woven Polyamide

- Fabric : 100% Polyamide. Woven fibers
- Recommended for all types of paint, solvent-based or water-based
- Ideal for intensive use
- High wear resistance
- Endless stable fibers, no shrinkage
- Excellent absorbency and coverage
- Uniform distribution of the paint
- No loss of fibres



Textured Polyamide

- Fabric : 100% Polyamide. Crimped endless fibres
- Recommended for filler acrylic coatings and paints as well as epoxy resins and dual-component paints
- Ideal for intensive use
- High wear resistance
- Excellent paint restitution
- High filling capacity
- No loss of fibres



Woven Polyester

- Fabric : 100% Polyester, woven endless fibres
- Recommended for acrylic paint
- Very high absorbency
- Fibres are highly resistant to abrasion
- No loss of fibres



HD Microfibre

- Fabric : high-density endless polyester microfibre
- Recommended for water-based paints
- Very high absorbency
- No dripping
- No loss of fibres



TechniFibre PA

- Hydrophobic fiber treatment
- Speeds up paint release
- Improves fiber strength and stability
- Makes cleaning easier



Matt polyamide

- Fabric : 100% Polyamide. Twisted fibres
- Recommended for all types of paint : solvent - based or water-based
- Ideal for intensive use
- High wear resistance
- Stable fibres, no shrinkage
- Excellent absorbency and coverage
- Uniform distribution of the paint

STORE YOUR BRUSHES AND ROLLERS



Accessories to store your rollers and reduce cleaning time

Roller saver – the quick and effective solution to keep your roller for several days

Airtight, Portable and compact: the Parfaitbox goes with you on site by clipping onto the trolley CODE 3760002.

MORE INFO
P.116

90 EACH PAINT HAS ITS OWN ROLLER !

	Recommended		Acrylic paint
	Suitable		Solvent phase paint
	Not suitable		Bio-based paint

TYPES OF PAINT >

FINITIONS >

WALL & CEILING PAINTS									TIGHT FINISH
VDC 2007 / 2010				VDC 2007 / 2010					
MATT	SATIN	VELVET		MATT	SATIN	VELVET			

SMOOTH SURFACES SHORT PILE



PAGE

ROLLER	DESCRIPTION	PAGE	MATT	SATIN	VELVET		MATT	SATIN	VELVET	TIGHT FINISH
	FOAM LACQUER No marks	92								
	HD FLOCKED FOAM Excellent covering and absorption capacity No marks	93								
	ANTI-STAIN LACQUER No marks	94								
	FLOCKED FOAM Excellent covering and absorption capacity No fibre loss	93								
	WOVEN POLYAMIDE Fills and resistant - No fibre loss	96		✓				●		
	AQUALISS'9 Non-drip - No fibre loss	96	●	✓	✓			●		
	MICROLISS'HD 6 Good cover and comfort of use High covering capacity - No fibre loss	97		✓	✓			●		
	MICROLISS'6 Good cover - No fibre loss	97		✓	✓			●		
	NON-DRIP POLYAMIDE Fills - No fibre loss. Excellent absorption and covering capacity Highly resistant to wear	98	●	✓	✓		●	●		✓

EVEN SURFACES SHORT PILE



ROLLER	DESCRIPTION	PAGE	MATT	SATIN	VELVET		MATT	SATIN	VELVET	TIGHT FINISH
	NON-DRIP POLYAMIDE No splatter - Good cover	99	●	●			✓	●		
	POLYGOLD 12 SUPER NON-DRIP No splatter - High covering capacity No fibre loss	100	●	●		●	✓	●		
	TECHNIFIBRE PA 12 No splatter - Good cover	101	●	●		✓	✓	●		
	SHORT TEXTURED Good fill and very resistant Very tight grain	101	✓	✓						✓
	MICROLISS' HD 12 High covering capacity and fill Great comfort of use - Quality finish	103	✓	●	✓	●				
	AQUALISS'13 No splatter - High covering capacity Optimum comfort of use - No fibre loss	102	✓	●						
	MICROLISS' 10 High absorption and covering capacity	103	✓	●	✓	●	●	●		
	MICROLISS' 14 Good fill and resistant - One coat on fibres and glass fabrics. Specially for primers and fixing agents	104	✓	●						

UNEVEN SURFACES LONG PILE



ROLLER	DESCRIPTION	PAGE	MATT	SATIN	VELVET		MATT	SATIN	VELVET	TIGHT FINISH
	OUTSIDE PAINTING Great absorption and covering	105								
	HIGH STRENGTH OUTSIDE PAINTING Great absorption and covering	105								
	TECHNIFIBRE PA 18 Irregular surface	106								
	OUTSIDE PAINTING HR 24 Great absorption and covering Heavy paint load	105								
	OUTSIDE PAINTING Great absorption and covering	107								
	WOVEN LONG POLYAMIDE For semi-thick and very thick coats. Fills and resistant. High covering capacity	106								



LACQUERS, DECORATIVE PAINTS				PRIMERS FIXING AGENTS	EXTERIOR PAINTS / WATERPROOFING AND SILOXANE			WOOD TREATMENT		FLOOR PAINTS		MARINE PAINTS	
							PLIOLITES	GLAZES	SEALANT	THIN	SEMI-THICK	FOULING	GELCOAT
GLOSS	MATT SATIN	GLOSS	MATT SATIN		THIN COAT	THICK SEMI-THICK COAT							

✓	●	✓	●						●				
✓	●	✓	●						●				
✓	✓	●	●						✓				
		✓	✓						✓				
	✓		●						●		✓		✓
	✓		●						●		●		
✓	✓		●					●	●				
✓	✓		●					●	●				
	●		✓						●	●			

										●	●		
										●	●		
										●	●		
										●	✓	●	✓
								✓	✓			●	
										●	●	●	
										●	●	●	

					✓	●	✓						
					✓	●	✓						
					✓	●							
					✓	●	✓						
					✓	●	✓						
					●	✓					✓		

OP PROCESS®

HAND TOOLS

ROLLERS & BRUSHES

OUR TIP

SMOOTH SURFACES LACQUERS, DECORATIVE PAINTS FOAM					WOOD TREATMENT		TIGHT FINISH
	GLOSS	MATT SATIN	GLOSS	MATT SATIN	GLAZES	SEALANT	
	✓	●	✓	●		●	

Foam Routine work

SMOOTH AND PREPARED SURFACES

Specifications

- Polyester foam
- 2 Straight edges
- Medium density

MINI ROLLER

Size	Packaging	CODE	
50 mm	20	4875005	1
70 mm	2*	7875070	10
110 mm	10	4875510	1
110 mm	2*	7875110	10

ROLLER

Size	CODE	
180 mm	876180	6

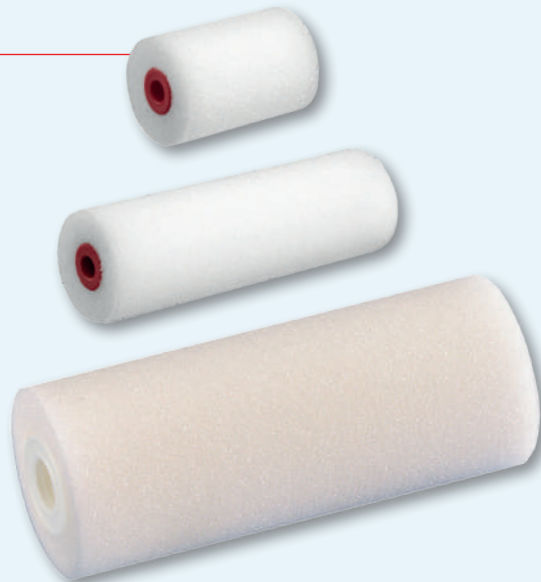

Foam lacquer roller

SMOOTH AND PREPARED SURFACES

VERY TIGHT FINISH

Specifications

- Flocked foam
- 2 Rounded edges for no mark
- High density

MINI ROLLER

Size	Packaging	CODE	
110 mm	2*	7879110	1
110 mm	10	4879510	1
150 mm	2*	7879150	1

ROLLER			COMPLETE MINI ROLLER BI MATERIAL FRAME		
Size	CODE		Size	CODE	
180 mm	875180	6	110 mm	193879029	10



Foam

ONE SOLID SIDE TO PREVENT PAINT MARKS.

Specifications

- High-Density Foam
- 2 straight edges + 2 anti-mark grooves

MINI ROLLER

Size	Packaging	CODE	
110 mm	10	4878110	1
110 mm	2*	7878110	1



* Mini rollers are generally sold in boxes of 10 or 20 (as indicated in the «packaging» column) except if they are sold in bags of 2.

OP PROCESS®

HAND TOOLS

ROLLERS & BRUSHES



OUR TIP

SMOOTH SURFACES LACQUERS, DECORATIVE PAINTS FOAM					WOOD TREATMENT		TIGHT FINISH
	GLOSS	MATT SATIN	GLOSS	MATT SATIN	GLAZES	SEALANT	
	✓	●	✓	●		●	

HD flocked foam lacquer roller

EXCELLENT COVERING AND ABSORBING POWER
GLOSS AND TIGHT FINISH

Specifications

- Flocked foam
- 2 rounded edges for no mark
- High density

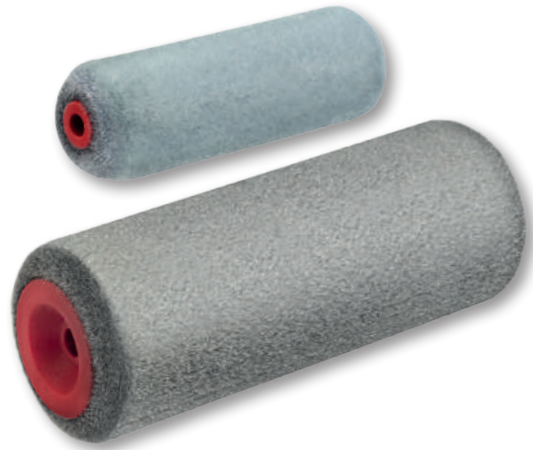

MINI ROLLER			
Size	Packaging	CODE	
110 mm	10	4877110	1

ROLLER		
Size	CODE	
180 mm	860180	6

Flocked foam lacquer roller

SMOOTH AND PREPARED SURFACES
GLOSS FINISH

Specifications

- Flocked foam
- Medium density



MINI ROLLER ROUNDED EDGES			
Size	Packaging	CODE	
70 mm	20	4679007	1
110 mm	2*	7679110	10
110 mm	10	4679510	1
150 mm	10	4679550	1

ROLLER STRAIGHT EDGES		
Size	CODE	
180 mm	975580	6

COMPLETE MINI ROLLER POLYPRO FRAME		
Size	CODE	
110 mm	2679110	6
150 mm	2679150	6

* Mini rollers are generally sold in boxes of 10 or 20 (as indicated in the «packaging» column) except if they are sold in bags of 2.

OUR TIP

SMOOTH SURFACES LACQUERS, DECORATIVE PAINTS SHORT PILE					WOOD TREATMENT		TIGHT FINISH
	GLOSS	MATT SATIN	GLOSS	MATT SATIN	GLAZES	SEALANT	
	✓	✓	●	●		✓	

Anti-stain lacquer 4 mm

SMOOTH AND PREPARED SURFACES
 FOR MATT, GLOSSY OR SATIN WATER-BASED LACQUERS
 EXTRA TIGHT FINISH
 EXCELLENT COVERAGE AND ABSORBENCY

Specifications

- Woven synthetic 4 mm
- High density
- Bevelled edges
- No fibre loss



MINI ROLLER

Size	Packaging	CODE	
50 mm	20	4610050	1
50 mm	20	4862050	1
110 mm	10	4862110	1
110 mm	2*	7862110	10
150 mm	10	4610150	1



MINI ROLLER LARGE DIAMETER Ø30

Size	Packaging	CODE	
110 mm	10	4944110	1
120 mm	1	3252120	10
150 mm	1	3252150	10



ROLLER

Size	CODE	
180 mm	862180	6



BEVELLED EDGES



MIXER AND ROLLER CLEANER

CLEAN YOUR ROLLERS EFFECTIVELY WITH THE MIXER/CLEANER
 CODE 3053000!

EXTEND THE LIFESPAN OF YOUR TOOLS.



2 FUNCTIONS IN 1 TOOL :
 IT ALSO ALLOWS YOU TO MIX YOUR PAINTS.



MORE P.117

* Mini rollers are generally sold in boxes of 10 or 20 (as indicated in the «packaging» column) except if they are sold in bags of 2.

OP PROCESS®

HAND TOOLS

ROLLERS & BRUSHES



OUR TIP

SMOOTH SURFACES LACQUERS, DECORATIVE PAINTS SHORT PILE					WOOD TREATMENT		TIGHT FINISH
	GLOSS	MATT SATIN	GLOSS	MATT SATIN	GLAZES	SEALANT	
			✓	✓		✓	

Lacquering velvet 4 mm

SATIN - TIGHT SMOOTH FINISH

Specifications

- Pure wool 4 mm



MINI ROLLER

Size	Packaging	CODE	
50 mm	20	4550050	1
110 mm	10	4550510	1
110 mm	2*	7550110	10
150 mm	10	4550550	1



MINI ROLLER LARGE DIAMETER Ø30

Size	Packaging	CODE	
110 mm	10	4923510	1



ROLLER

Size	CODE	
180 mm	976580	6



COMPLETE ROLLER

Size	CODE		
50 mm	193550019	10	BIMATERIAL FRAME
110 mm	193550029	10	BIMATERIAL FRAME
180 mm	2976580	1	POLYPRO FRAME

BEVELLED EDGES



ParfaitBox®

CLEAN... OR STORE YOUR ROLLER SLEEVES AND BRUSHES IN THE PARFAITBOX!

SAVE TIME ON YOUR JOB SITES: THE NEXT DAY, YOUR TOOLS ARE READY TO USE!



MORE P.116

* Mini rollers are generally sold in boxes of 10 or 20 (as indicated in the «packaging» column) except if they are sold in bags of 2.

OUR TIP

SMOOTH SURFACES SHORT PILE	WATER			SPRAYER		WOOD TREATMENT	FLOOR PAINTS	MARINE PAINTS	SEMI-TIGHT FINISH
	GLOSS	SATIN	MATT	SATIN	MATT	SEALTANT	HALBDICK	GELCOAT	
LACQUERS, DECORATIVE PAINTS		✓	✓	●	●	●	●	✓	
WALL & CEILING PAINTS		✓		●				✓	

Woven polyamide 7 mm

MEDIUM SMOOTH COVERING
GOOD COVERING POWER - NO FIBRE LOSS

Specifications

- Textured polyamide 7 mm

MINI ROLLER

Size	Packaging	CODE	
110 mm	10	4947110	1
110 mm	2*	7647110	10

ROLLER

Size	CODE	
180 mm	857180	6
250 mm	857250	6



BEVELLED EDGES

AquaLiss'6 mm

COMPACTED GRAIN FINISH
STRONG OPACITY - NO FIBRE LOSS

Specifications

- Woven polyester 6 mm

MINI ROLLER

Size	Packaging	CODE	
110 mm	10	4684110	1

ROLLER

Size	CODE	
180 mm	684180	6



BEVELLED EDGES AND REVERTED EDGES

AquaLiss'9 mm

TIGHT GRAIN, TEXTURED SATIN FINISH
NO SPATTER

Specifications

- Woven polyester 9 mm

MINI ROLLER

Size	Packaging	CODE	
110 mm	10	4889110	1
110 mm	2	7889110	1

ROLLER

Size	CODE	
180 mm	889180	6
250 mm	889250	6



BEVELLED EDGES AND REVERTED EDGES

* Mini rollers are generally sold in boxes of 10 or 20 (as indicated in the «packaging» column) except if they are sold in bags of 2.

OP PROCESS®

HAND TOOLS

ROLLERS & BRUSHES



OUR TIP

SMOOTH SURFACES SHORT PILE							WOOD TREATMENT		SEMI-TIGHT FINISH
	GLOSS	SATIN	MATT	GLOSS	SATIN	MATT	GLAZES	SEIGELLACKE	
LACQUERS, DECORATIVE PAINTS	✓	✓	✓		●	●	●	●	
WALL & CEILING PAINTS		✓							

MicroLiss'HD 6 mm

TIGHT FINISH
HIGH OPACITY AND COMFORT OF USE
HIGH COVERAGE
NO FIBRE LOSS

Specifications

- Polyester microfibre 6 mm
- High density



MINI ROLLER

Size	Packaging	CODE	
50 mm	20	4932050	1
110 mm	10	4932110	1
110 mm	2*	7932110	10
110 mm	5	4932115	1



MINI ROLLER LARGE DIAMETER Ø30

Size	Packaging	CODE	
110 mm	1	3934110	10



ROLLER

Size	CODE	
180 mm	880180	6
220 mm	880220	6
250 mm	880250	6



BEVELLED EDGES
AND REVERTED
EDGES

MicroLiss'6 mm

TIGHT TEXTURED FINISH - GOOD OPACITY
HIGH COVERING CAPACITY

Specifications

- Polyester microfibre 6 mm



MINI ROLLER

Size	Packaging	CODE	
110 mm	10	4553510	1
110 mm	2*	7553110	10



MINI ROLLER LARGE DIAMETER Ø30

Size	Packaging	CODE	
110 mm	10	4941110	1



ROLLER

Size	CODE	
180 mm	984180	6
220 mm	984220	6
250 mm	984250	6



BEVELLED EDGES
AND REVERTED
EDGES

* Mini rollers are generally sold in boxes of 10 or 20 (as indicated in the «packaging» column) except if they are sold in bags of 2.

OUR TIP

SMOOTH SURFACES SHORT PILE	WATER			SPRAY			WOOD TREATMENT		METALS	SEMI-TIGHT FINISH
	GLOSS	SATIN	MATT	GLOSS	SATIN	MATT	GLAZES	SIEGELLACKE		
LACQUERS, DECORATIVE PAINTS		●	●		✓	✓		●	✓	
WALL & CEILING PAINTS		✓	●		✓	●				

Non-Drip Polyamide 9 mm

EXCELLENT ABSORBENCY AND COVERAGE
TIGHT GRAIN FINISH

Specifications

- Polyamide 9 mm
- **Endless fibers**

Size	CODE	ROLLER
180 mm	882180	6

BEVELLED EDGES
AND REVERTED
EDGES



OUR TIP

REGULAR AND IRREGULAR SURFACES	PRIMERS / UNDERCOATS / FIXERS
	✓

Short polyester 12 mm

ALL PAINTS - PRIMER, UNDERCOAT & FIXER

Specifications

- Short polyester 12 mm

Size	CODE	ROLLER
80 mm	969080	6
180 mm	969580	6
250 mm	969550	6

Size	CODE	COMPLETE ROLLER POLYPRO FRAME
180 mm	2969580	1



Long polyester 18 mm

FOR FIXING AGENT - UNDERCOAT

Specifications

- Long polyester 18 mm

Size	CODE	ROLLER
80 mm	970080	6
180 mm	970580	6
250 mm	970550	6

Size	CODE	COMPLETE ROLLER POLYPRO FRAME
180 mm	2970580	1
250 mm	2970550	1



OP PROCESS®

HAND TOOLS

ROLLERS & BRUSHES



OUR TIP

EVEN SURFACES SHORT PILE					FLOOR PAINTS		MARINE PAINTS		TEXTURED FINISH
	MATT	SATIN	MATT	SATIN	THIN	SEMI-THICK	ANTI FOULING	GELCOAT	
WALL & CEILING PAINTS	●	●	✓	●		●		●	

Non-Drip Polyamide 12 mm

GIVES A GRAINED TEXTURE
GOOD COVERING POWER

Specifications

- Woven polyamide 12 mm
- Stitched assembly



MINI ROLLER

Size	Packaging	CODE	
50 mm	20	4991050	1
110 mm	10	4991510	1
110 mm	2*	7991110	10
150 mm	10	4991550	1



MINI ROLLER LARGE DIAMETER Ø30

Size	Packaging	CODE	
110 mm	10	4927510	1



ROLLER

Size	CODE	
180 mm	866180	6
220 mm	866220	6
250 mm	866250	6



COMPLETE ROLLER POLYPRO FRAME

Size	CODE	
50 mm	193991019	10
180 mm	2866180	1
250 mm	2866250	1
Bi-material frame		
110 mm	193991029	10

REVERTED EDGES



OP PROCESS®

HAND TOOLS

ROLLERS & BRUSHES

OUR TIP

EVEN SURFACES SHORT PILE					FLOOR PAINTS		MARINE PAINTS		TEXTURED FINISH
	MATT	SATIN	SATIN	MATT	THIN	SEMI-THICK	ANTI FOULING	GELCOAT	
WALL & CEILING PAINTS	●	●	✓	●		●	●		

POLYGOLD 12 Super Non-Drip 12 MM

DAPPLED FINISH - HIGH COVERING POWER
NO FIBRE LOSS

Specifications

- Polyamide 12 mm
- Endless thread

MINI ROLLER			
Size	Packaging	CODE	
110 mm	10	4933110	1
110 mm	2*	7933110	10

ROLLER		
Size	CODE	
180 mm	873180	6
250 mm	873250	6

BEVELLED EDGES
AND REVERTED EDGES



Extra Non-drip Polyamide 12 mm Ø65

GIVES A GRAINED TEXTURE
GOOD COVERING POWER

Specifications

- Woven polyamide 12 mm
- Heat sealed

ROLLER LARGE DIAMETER		
Size	CODE	
180 mm	3266180	6
250 mm	3266250	6



OP PROCESS® FRAME

USE THE NEW OP PROCESS® SCREW-ON MOUNT, AVAILABLE IN SIZES FROM 40 MM TO 250 MM.

MOUNTING FOR SCREWING ON TO OP PROCESS® POLES
CODE 1766.

- 1 POLE = MULTIPLE USES**
THE OP PROCESS® POLE ALSO ALLOWS YOU TO SCREW IN CONNECTORS FOR YOUR PARFAITLISS® OR TRIFLEX® BLADES.

MORE P.112



* Mini rollers are generally sold in boxes of 10 or 20 (as indicated in the «packaging» column) except if they are sold in bags of 2.

OP PROCESS®

HAND TOOLS

ROLLERS & BRUSHES



OUR TIP

EVEN SURFACES SHORT PILE					FLOOR PAINTS		MARINE PAINTS		TEXTURED FINISH
	SATIN	MATT	SATIN	MATT	THIN	SEMI-THICK	ANTI FOULING	GELCOAT	
WALL & CEILING PAINTS	✓	✓			●		●	✓	

Short textured 12 mm

MATT AND SATIN FINISH - FILLING AND RESISTANT
VERY TIGHT GRAIN

Specifications

- Textured polyamide 12 mm

MINI ROLLER			
Size	Packaging	CODE	
110 mm	10	4920510	1
110 mm	2*	7920110	10

MINI ROLLER LARGE DIAMETER Ø30			
Size	Packaging	CODE	
110 mm	10	4552110	1

ROLLER			COMPLETE ROLLER POLYPRO FRAME		
Size	CODE		Size	CODE	
180 mm	972580	6	180 mm	2972580	1
250 mm	972250	6			



TechniFibre'PA 12 mm

OPTIMISED FINISH AND OPACITY - EASY TO CLEAN
ANTI-SPRAY

Specifications

- Coated polyamide
- 12 mm endless double weave yarn

MINI ROLLER			
Size	Packaging	CODE	
110 mm	10	4828110	1
110 mm	2*	7828110	10

ROLLER		
Size	CODE	
180 mm	828180	6
250 mm	828250	6



TechniFibre'PA

NEW WEAVING TECHNIQUE : INCREASES PAINT LOAD CAPACITY AND ROLLER COVER SATURATION.
ENHANCES YARN RESILIENCE FOR SMOOTH, COMFORTABLE APPLICATION.

HYDROPHOBIC FIBER TREATMENT : SPEEDS UP PAINT RELEASE. IMPROVES FIBER STRENGTH AND STABILITY.
MAKES CLEANING EASIER.

AN EXCELLENT BALANCE OF RESILIENCE, DURABILITY, AND LONG-LASTING PERFORMANCE.

* Mini rollers are generally sold in boxes of 10 or 20 (as indicated in the «packaging» column) except if they are sold in bags of 2.

OUR TIP

EVEN SURFACES SHORT PILE	WATER		PAINT		FLOOR PAINTS		MARINE PAINTS		TEXTURED FINISH
	MATT	SATIN	SATIN	MATT	THIN	SEMI-THICK	ANTI FOULING	GELCOAT	
WALL & CEILING PAINTS	✓	●			●		●		

AquaLiss'13 mm

DAPPLED FINISH - VERY GOOD COMFORTABLE OF USE
ANTI-SPLATTER - HIGH COVERING POWER
- NO FIBRE LOSS

Specifications

- Woven polyester 13 mm



MINI ROLLER

Size	Packaging	CODE	Icon
110 mm	10	4937110	1
110 mm	2*	7937110	10



ROLLER

Size	CODE	Icon
180 mm	871180	6
220 mm	871220	6
250 mm	871250	6

BEVELLED EDGES
AND REVERTED
EDGES



OUR TIP

EVEN SURFACES SHORT PILE	WATER		PAINT		FLOOR PAINTS		MARINE PAINTS		TEXTURED FINISH
	MATT	SATIN	SATIN	MATT	THIN	SEMI-THICK	ANTI FOULING	GELCOAT	
WALL & CEILING PAINTS	●	●	✓	●		●	●		

Non drip twister sleeve 14 mm

REGULAR SURFACES AND GLASS CLOTH
HIGH ABSORBENCY AND COVERAGE
NO FIBRE LOSS

Specifications

- Woven polyamide 14 mm



ROLLER

Size	CODE	Icon
180 mm	870580	6

REVERTED AND
BEVELLED EDGES



* Mini rollers are generally sold in boxes of 10 or 20 (as indicated in the «packaging» column) except if they are sold in bags of 2.



OUR TIP

EVEN SURFACES SHORT PILE					WOOD TREATMENT		DAPPLED FINISH
	MATT	SATIN	MATT	SATIN	GLAZES	SEALANT	
WALL & CEILING PAINTS	✓	●			✓	✓	

MicroLiss'HD 12 mm

SMOOTH FINISH
STRONG OPACITY AND EASY APPLICATION

Specifications

- Polyester microfiber 12 mm
- High density



MINI ROLLER

Size	Packaging	CODE	
110 mm	10	4935110	1
110 mm	2*	7935110	10
110 mm	1	3933110	10



ROLLER

Size	CODE	
180 mm	872180	6
250 mm	872250	6



BEVELLED EDGES
AND REVERTED
EDGES

MicroLiss'10 mm

SEMI-TIGHT FINISH
HIGH ABSORBENT CAPACITY

Specifications

- Polyester microfibre 10 mm



MINI ROLLER

Size	Packaging	CODE	
50 mm	20	4994050	1
110 mm	10	4994110	1
110 mm	2	7994110	10



MINI ROLLER LARGE DIAMETER Ø30

Size	Packaging	CODE	
110 mm	10	4942110	1



ROLLER

Size	CODE	
180 mm	988180	6
250 mm	988250	6



COMPLETE ROLLER POLYPRO FRAME

Size	CODE	
180 mm	2988180	6



BEVELLED EDGES
AND REVERTED
EDGES

* Mini rollers are generally sold in boxes of 10 or 20 (as indicated in the «packaging» column) except if they are sold in bags of 2.

OUR TIP

EVEN SURFACES SHORT PILE					DAPPLED FINISH
	MATT	SATIN	SATIN	MATT	
WALL & CEILING PAINTS	✓	●			

MicroLiss'14 mm

SEMI-TIGHT FINISH
SINGLE COAT ON FIBER GLASS PAPER

Specifications

- Microfibre 14 mm

MINI ROLLER			
Size	Packaging	CODE	
110 mm	20	4554110	1

MINI ROLLER LARGE DIAMETER Ø30			
Size	Packaging	CODE	
110 mm	10	4943110	1

ROLLER		
Size	CODE	
180 mm	877180	6

COMPLETE ROLLER POLYPRO FRAME		
Size	CODE	
180 mm	2877180	10



BEVELLED EDGES
AND REVERTED
EDGES

MicroLiss'HD 18 mm

SMOOTH FINISH
STRONG OPACITY AND EASY APPLICATION

Specifications

- Polyester microfiber 18 mm
- High density

ROLLER		
Size	CODE	
180 mm	863180	6
250 mm	863250	6



BEVELLED EDGES
AND REVERTED
EDGES

* Mini rollers are generally sold in boxes of 10 or 20 (as indicated in the «packaging» column) except if they are sold in bags of 2.

OP PROCESS®

HAND TOOLS

ROLLERS & BRUSHES



OUR TIP

UNEVEN SURFACES LONG PILE	WATERPROOFING AND SILOXANE			STRUCTURED FINISH	
	THIN COATS		THICK SEMI- THICK COATS		PLIOLITES
	✓		●		✓

Outside painting 18 mm

THIN AND SEMI THICK COAT AND PLIOLITE SOLVENT PHASE PAINT

Specifications

- Twisted polyamide 18 mm

MINI ROLLER
LARGE DIAMETER Ø30

Size	Packaging	CODE	
110 mm	10	4940510	1
110 mm	5	4940515	1

ROLLER

Size	CODE	
180 mm	973580	6
220 mm	973220	6
250 mm	973550	6

COMPLETE ROLLER
LARGE DIAMETER Ø30
POLYPRO FRAME

Size	CODE	
Ø30-110 mm	2940110	1
180 mm	2973580	1



BEVELLED EDGES AND REVERTED EDGES

High strength Outside painting 20 mm

GOOD COVERING POWER
GOOD ABSORPTION

Specifications

- Twisted polyamide 20 mm

ROLLER

Size	CODE	
180 mm	869180	6
250 mm	869250	6

COMPLETE ROLLER
POLYPRO FRAME

Size	CODE	
180 mm	2869180	1



BEVELLED EDGES AND REVERTED EDGES

OUR TIP

UNEVEN SURFACES LONG PILE	WATERPROOFING AND SILOXANE			STRUCTURED FINISH	
	THIN COATS		THICK SEMI- THICK COATS		PLIOLITES
	●		●		✓

Outside painting 'HR 24 mm

THIN AND SEMI-THICK COAT AND PLIOLITE SOLVENT AND WATERBORNE FILLING POWER WITH CONSTANT DEPOSIT THICKNESS

Specifications

- 24 mm Twisted polyamide
- Continuous thread

ROLLER

Size	CODE	
180 mm	965180	6
250 mm	965250	6



BEVELLED EDGES AND REVERTED EDGES

OP PROCESS®

HAND TOOLS

ROLLERS & BRUSHES



OUR TIP

UNEVEN SURFACES
LONG PILE

WATERPROOFING AND SILOXANE		
THIN COATS	THICK SEMI- THICK COATS	PLIOLITES
●	✓	

STRUCTURED FINISH

Non-drip polyamide large diameter 12 mm Ø65

IRREGULAR SURFACES, FACADES - EXTERIOR CLADDING

Specifications

- Polyamide extra 12 mm
- Diameter 65 mm
- Endless fiber



ROLLER
LARGE DIAMETER Ø65

Size	CODE	
180 mm	3255180	6

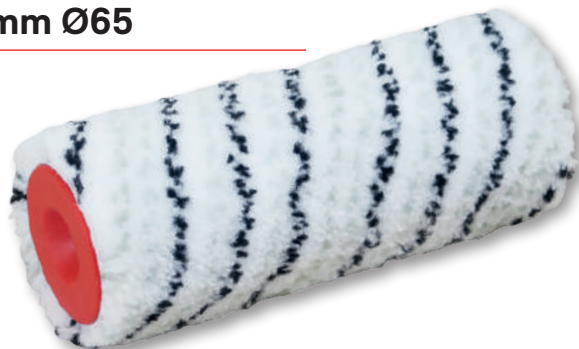

Outside painting large diameter 18 mm Ø65

UNEVEN SURFACES, FACADES
ABSORBENT, COVERING AND RESISTANT

Specifications

- Twisted polyamide 18 mm



ROLLER
LARGE DIAMETER Ø65

Size	CODE	
180 mm	3267180	6
250 mm	3267250	6



OUR TIP

UNEVEN SURFACES
LONG PILE

WATERPROOFING AND SILOXANE		
THIN COATS	THICK SEMI- THICK COATS	PLIOLITES
●	●	✓

STRUCTURED FINISH

Outside painting 20 mm Monted on Foam

SEMI-THICK TO THICK FILM AND PLIOLITE
HIGHLY ABSORBENT AND COVERING
VERY RESISTANT

Specifications

- 20 mm Twisted polyamide
- Mounted on foam



ROLLER

Size	CODE	
180 mm	900580	6
250 mm	900550	6

BEVELLED EDGES
AND REVERED EDGES



Flexible Outside Painting 21 mm Mounted on Foam

ALSO FOR THE IMPREGNATION OF GLASS FIBRES
HIGHLY ABSORBENT AND COVERING
VERY RESISTANT

Specifications

- 21 mm Polyamide
- Sewn
- Mounted on foam



ROLLER

Size	CODE	
180 mm	3253180	6
250 mm	3253250	6

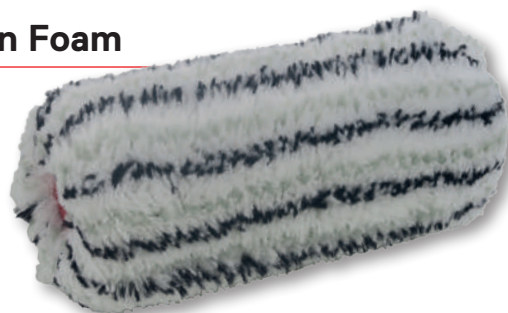

OP PROCESS®

HAND TOOLS

ROLLERS & BRUSHES

Short Polyester 12 mm

UNDERCOATS AND PRIMERS - ALL WORKS

Specifications

- Polyester 12 mm

COMPLETE ROLLER POLYPRO FRAME		
Size	CODE	
180 mm	2961580	10



Anti-Drip Extra 12 mm

ANTI-PROJECTION - GOOD COVERING POWER
ALL MATT AND SATIN PAINTS

Specifications

- Polyester 12 mm

ROLLER DISPENSER BOX		COMPLETE ROLLER POLYPRO FRAME		
Size	CODE		CODE	
180 mm	1273180	24	2963580	10
250 mm	1273250	18	2963550	6



Acrylic Dripstop 12 mm

ACRYLIC MATT AND SATIN PAINTS
HIGH COVERING POWER

Specifications

- Woven polyester 12 mm

ROLLER DISPENSER BOX		COMPLETE ROLLER POLYPRO FRAME		
Size	CODE		CODE	
180 mm	1279180	24	2965180	10
250 mm			2965250	6



Microfiber 9 mm

ALL PAINTS - MATT AND SATIN FINISH

Specifications

- Microfibre 9 mm

ROLLER DISPENSER BOX		COMPLETE ROLLER POLYPRO FRAME		
Size	CODE		CODE	
180 mm	887180	24	3887180	10

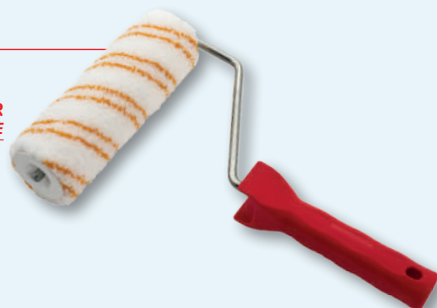

Outside paints - Long 18 mm

THIN TO SEMI THICK COAT

Specifications

- Twisted polyacrylic 18 mm

ROLLER DISPENSER BOX		COMPLETE ROLLER POLYPRO FRAME		
Size	CODE		CODE	
180 mm	1277180	24	2964580	10
250 mm	1277550	18	2964550	6



Long Polyester 18 mm

ALL PAINTS

Specifications

- Polyester 18 mm
- Tube ø 47mm

COMPLETE ROLLER POLYPRO FRAME		
Size	CODE	
180 mm	2960580	10
250 mm	2960550	6





Polyester foam

ALL PAINTS, LACQUERS AND VARNISHES

Specifications

- Polyester foam
- Medium density



COMPLETE ROLLER
POLYPRO FRAME

Size	CODE	
180 mm	964580	10

Lacquer Roller

FOR GLOSSY LACQUERS AND SOLVENT BORNE VARNISHES TIGHT FINISH

Specifications

- Pure wool 4 mm



COMPLETE ROLLER
POLYPRO FRAME

Size	CODE	
180 mm	963580	10

Non-drip Microfiber 10 mm

MEDIUM SMOOTH FINISH ON REGULAR SURFACES

Specifications

- Polyester microfibres 10 mm



COMPLETE ROLLER
POLYPRO FRAME

Size	CODE	
180 mm	986180	10
250 mm	986250	10

Short non drip 12 mm

ALL PAINTS MATT AND SATIN FINISH

Specifications

- Polyester 12 mm



COMPLETE ROLLER
POLYPRO FRAME

Size	CODE	
180 mm	946180	10

Acrylic paint 12 mm

Specifications

- Polyester 12 mm



COMPLETE ROLLER
POLYPRO FRAME

Size	CODE	
180 mm	962580	10

Polyester 12 mm

UNDERCOATS, PRIMERS

Specifications

- Polyester 12 mm



COMPLETE ROLLER
POLYPRO FRAME

Size	CODE	
180 mm	961580	10

Long polyester 18 mm

EXTERIOR PAINTS

Specifications

- Polyester 18 mm



COMPLETE ROLLER
POLYPRO FRAME

Size	CODE	
180 mm	960580	10

Outside painting 18 mm

EXTERIOR PAINTS

Specifications

- Long pile polyacrylique 18 mm



COMPLETE ROLLER
POLYPRO FRAME

Size	CODE	
180 mm	966180	10

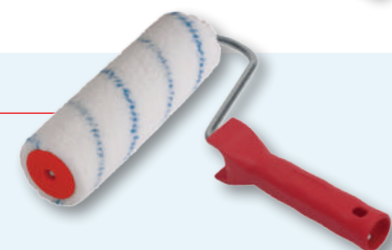

Floor Painting

FLOOR PAINT, RESINS & EPOXY - SOLVENT PHASE

Specifications

- Polyamide 12 mm
- New anti-friction / anti-spray cap for the 500 mm rollers



ROLLER

Size	CODE	
250 mm	1320550	6
500 mm	1320500	6



Floor Painting

WATER-GLYCERO PHASE - SEMI-TIGHT FINISH
HIGH ABSORBENT CAPACITY

Specifications

- Polyester microfibre 10 mm
- Screw type
- New anti-friction / anti-spray cap



ROLLER

Size	CODE	
500 mm	1325500	6



MicroLiss'HD 12

SMOOTH FINISH
STRONG OPACITY AND EASY APPLICATION

Specifications

- Polyester microfibre 12 mm
- High density
- New anti-friction / anti-spray cap for the 500 mm roller



ROLLER
BEVELLED & REVERSED EDGES

Size	CODE	
250 mm	872250	6
500 mm	872500	6



AquaLiss'13

DAPPLED FINISH - WATER PHASE - VERY GOOD COMFORTABLE
OF USE - ANTI-SPLATTER - HIGH COVERING POWER
- NO FIBRE LOSS

Specifications

- Woven polyester 13 mm
- New anti-friction / anti-spray cap for the 500 mm roller



ROLLER
BEVELLED & REVERSED EDGES

Size	CODE	
500 mm	871500	6



Floor Painting

FLOOR PAINT, RESINS & EPOXY - SOLVENT PHASE

Specifications

- Polyamide 12 mm
- New anti-friction / anti-spray cap for the 500 mm rollers



ROLLER

Fiber	Size	CODE	
7 mm	500 mm	1322500	6
12 mm	500 mm	972500	6
18 mm	500 mm	868500	6

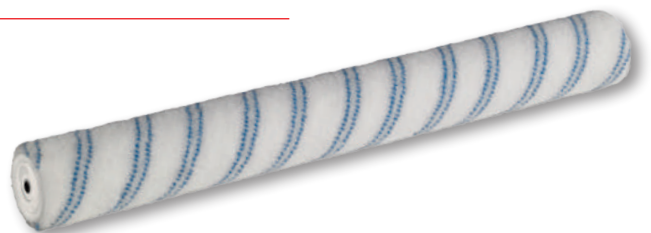

Parfait'Bac®

THE PARFAITBAC® IS SPECIALLY DESIGNED TO USE 500 MM ROLLS: DELIVERED WITH ITS 3 ECO-REFILLS, IT MOVES EASILY THANKS TO ITS WHEELS.



MORE P.117



Spike roller

TO REMOVE BUBBLES FROM PAINTS AND FLOOR RESINS

Specifications

- Plastic spikes
- Can be used with pole



COMPLETE ROLLER

Size	CODE		
180 mm	1880580	1	POLYPRO FRAME
250 mm	1880550	1	POLYPRO FRAME
500 mm	1880500	1	ALUMINIUM FRAME



Spike roller

TO REMOVE BUBBLES FROM PAINTS AND FLOOR RESINS

Specifications

- Plastic spikes 11 mm
- Ball-tipped injected polypropylene



ROLLER

Size	CODE	
180 mm	1882180	1
250 mm	1882250	1
500 mm	1882500	1



Floor painting roller Y-frame

ROLLER FRAME FOR 500 MM ROLLERS
DOUBLE ARM
WITHOUT AXLE - FIXED STOP

Specifications

- Steel wire diameter 8 mm
- Shaftless - Fixed stop

Size	CODE	
500 mm	1323500	1

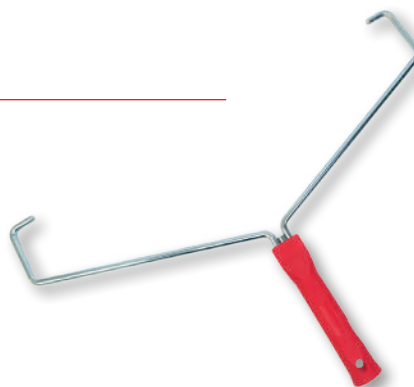

Adjustable frame

NEW

FOR 300 TO 500 MM SLEEVES

Specifications

- Screw-on handle for OP Process® poles Ref.1766
- With centring mark
- Screw-on tip
- Aluminium support

Size	CODE	
300-500 mm	1324000	1

OP Process®
extension pole
1766

More information p. 24

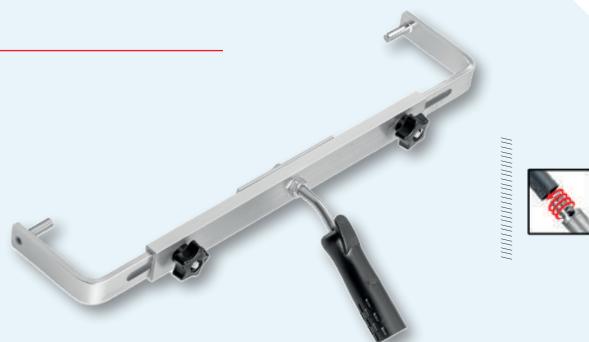

THE WINNING
COMBINATION

OP PROCESS® POLE AND
ADJUSTABLE FRAME

OP Process'® Frame Ø8

NEW

IMPROVES THE RIGIDITY OF THE POLE/FRAME/ROLLER CONNECTION
SCREW-ON TIP



Specifications

- Mounting for screwing on to OP Process'® poles code 1766
- Ø8 mm

Size	CODE	
40 mm	1770040	1
80 mm	1770080	1
180 mm	1770180	1
220 mm	1770220	1
250 mm	1770250	1



Aluminium frame Ø8

PROFESSIONAL QUALITY - 50% LIGHTER - ANTI-DRIP SHAPE

Specifications

- Ergonomic hollow bi-material handle
- Rilsan®-coated 8 mm Aluminum Rod

Size	CODE	
180 mm	2981580	6
250 mm	2981250	6



Roller Frame Ø8

QUICK CLIP LINE SYSTEM

Specifications

- **Hollow bi-material handle**
- White zinc-plated rod 8 mm

Size	CODE	
180 mm	2967180	6
250 mm	2967250	6



Roller Frame Ø8

QUICK MOUNTING OF ROLLERS

Specifications

- White galvanised rod Ø8 mm
- Hollow polypropylene handle

Size	CODE	
80 mm	967080	6
180 mm	967580	6
220 mm	967220	6
250 mm	967550	6



Roller Frame Ø8

Specifications

- Hollow polypropylene handle
- Galvanised wire rod diameter 8 mm

Size	CODE	
180 mm	1993180	6
220 mm	1993220	1
250 mm	1993250	6





Mini roller Frame Ø6 mm

Specifications

- Polypropylene ergonomic hollow handle
- Galvanised wire rod Diameter 6 mm
- Length 19 cm for 50 mm rollers
- Length 29, 40 and 55 for 110 and 150 mm rollers
- Clip system

Length	CODE	
19 cm	992019	6
29 cm	992529	6
40 cm	992540	6
55 cm	992555	6



Mini roller Frame Ø6 mm

Specifications

- Polypropylene ergonomic hollow handle
- Galvanised wire rod Ø6 mm
- Clip system

Length	Size	CODE	
27 cm	50 mm	99200535	6
30 cm	150 mm	99201535	6



Roller frame Ø6 mm

QUICK CLIP LINE SYSTEM

Specifications

- Polypropylene ergonomic hollow handle
- Galvanised wire rod diameter 6 mm
- For pole

Size	CODE	
180 mm	2998180	6

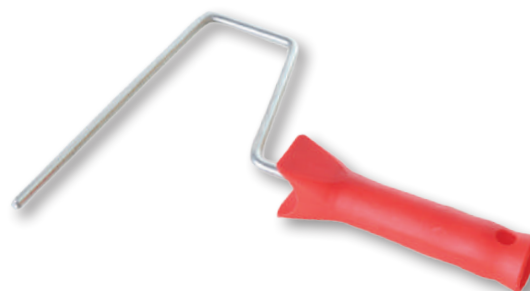

Mini roller Frame Ø6 mm

Specifications

- Hollow bi-material handle
- White zinc-plated rod 6 mm

Length	CODE	
29 cm	2992029	6
40 cm	2992040	6
55 cm	2992055	6

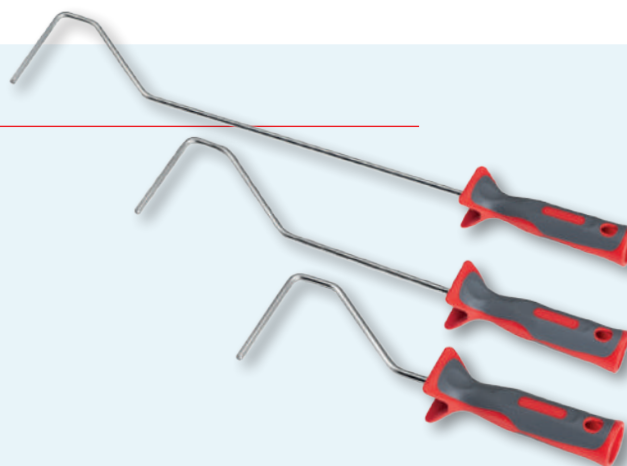



OP Process® extension pole

NEW

NEW OP PROCESS® SCREW-ON TOOLING CONCEPT : TELESCOPIC POLE THAT CAN BE CUSTOMISED TO SUIT THE NATURE OF THE WORKSITE
NEW SCREW-ON SYSTEM: 1 POLE = 7 USES

Specifications

- 3 aluminium sections
- 2 black soft grip handles
- Head with anti-rotation and anti-pull-out clips

Size	CODE	
2 x 0.7 m	1766070	6
2 x 1 m	1766100	6



Frame connector

EXCELLENT BALANCE BETWEEN LIGHTNESS AND STRENGTH

Specifications

- Universal connector for hollow handle
- Screw-on tip
- With anti-rotation fixing lugs
- For OP Process® pole Ref. 1766

CODE	
3480000	1



Multi-tool connector

NEW OP PROCESS® COMPACT TOOLING CONCEPT

Specifications

- Screw-on composite pole tip
- Spikes for plastering and stripping knives
- Fixing system with handle centring device
- System screw in centre

CODE	
3348000	1



Extension pole

TELESCOPIC POLE WITH LUG ATTACHMENT SYSTEM

Specifications

- Aluminium tubes
- Cam locking system
- Clip-on pole head
- Rubberised handle

Size	CODE	
2 x 0.70 m	1480070	4



Multipurpose pole

ADAPTABLE TO MANY TOOLS - CAN BE USED WITH ROLLERS, BRUSHES, KNIVES, SCRAPERS...

ADJUSTABLE UPPER HEAD - SCREW SYSTEM IN THE CENTRE

Specifications

- 2 ultra-light ribbed aluminium sections
- Fixing system with handle centring device
- Cam locking system

Size	CODE	
2 x 0.70 m	1348070	4
2 x 1.00 m	1348100	4
2 x 1.50 m	1348150	4





Rectangular Bucket

MULTI-PURPOSE ECO-CONCEPT PAINT BUCKET
SUPPLIED WITH 5 DISPOSABLE FILMS

Specifications

- Polypropylene bucket with metal handle
- Peel-off films made of recycled material, easily removable

Capacity	Size	CODE	
7 l	290x200x190mm	3758007	12
14 l	365x280x220mm	3693000	12



Bucket

NEW

MULTI-PURPOSE PAINT BUCKET

Specifications

- Recycled polypropylene Bucket
- Non-drip spout
- Metal handle

Capacity	Size	CODE	
8 l	303x224x184mm	3685008	20
12 l	371x261x203mm	3685012	10
LS REFILLS x5			
8 l		3684008	15
12 l		3684012	10



Multipurpose soft bucket

FLEXIBLE, LIGHT AND RESISTANT
ALSO FOR MIXING PASTE, PLASTER, RESIN AND COATINGS

Specifications

- Black rubberised material

Capacity	Size	CODE	
42 l	Ø 490/430xH.385mm	1620038	12



Mixer and roller cleaner

NEW

2 FUNCTIONS IN A SINGLE ACCESSORY:
MIXING PADDLE FOR LIQUID MATERIALS SUCH AS PAINT,
AND CLEANING SUPPORT FOR ROLLERS AND ROLL'ENDUIT.

Specifications

- Galvanized steel round rod Ø8 mm
- Polypropylene head Ø9 x 9 cm
- 12-blade rotor turbine

CODE	
3053000	6

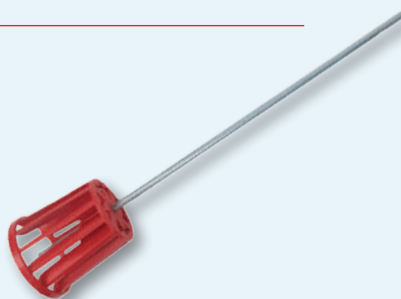

MIXER
MIXING PADDLE FOR
LIQUID MATERIALS
SUCH AS PAINT



CLEANER
CLEANING SUPPORT
FOR ROLLERS AND
ROLL'ENDUIT



Angle knife

SPECIALLY DESIGNED FOR THE INSTALLATION OF FABRICS AND STRETCH CEILINGS

Specifications

- Rounded stainless steel blade
- PEFC beech wood handle

Size	CODE	
12 cm	515000	1



STAINLESS STEEL

Papering knife

TO SMOOTH AND PRESS DOWN WALLPAPER

Specifications

- High strength polystyrene
- Flexible
- Triangular shape
- 17 cm per base

Size	CODE	
17 cm	540000	1



Papering knife

SMOOTHING OUT AND CUTTING GUIDE ALL WALL COVERINGS

Specifications

- Plastic, hangeable
- Rigid

Size	CODE	
26x16 & 11 cm	542000	10



Papering knife

SMOOTHING OUT AND CUTTING GUIDE RIGID

Specifications

- Transparent shock-proof ABS, hangeable
- One-piece, built-in handle

Size	CODE	
26x15.5 & 12 cm	1792000	10

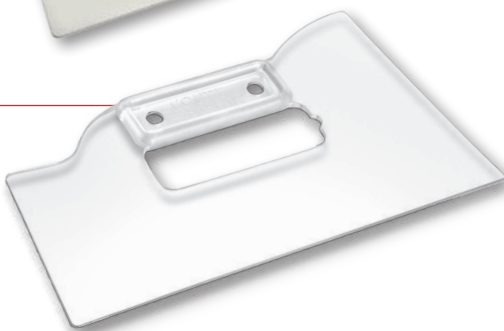

Papering knife

TO SMOOTH AND PRESS DOWN WALLPAPER RIGID - ROUNDED EDGES

Specifications

- Made of rigid polyethylene
- Trapezoidal

Size	CODE	
23 x 12 cm	1443000	1



Stainless steel papering knife

FOR TAMPING AND GUIDING THE CUTTING OF FLOOR AND WALL COVERINGS ROUNDED EDGES - RIGID

Specifications

- Stainless steel blade
- PEFC beech wood handle

Size	CODE	
34 cm	547000	1



STAINLESS STEEL



Mix of natural & synthetic bristles124 at
..... 127

Synthetic fibres128 at 130

Wood treatment 131

Black fibres 127

Aquasilver 128 and 129

TechniFil' 130

Self-service range132 at 135

Cleaning brush 136

BRUSHES

122 EACH PAINT HAS ITS OWN BRUSH !

	Recommended		Acrylic paint	TYPES OF PAINT >	WALL & CEILING PAINTS						TIGHT FINISH		
	Suitable		Solvent phase paint			VDC 2007 / 2010				VDC 2007 / 2010			
	Not suitable		Bio-based paint		FINITIONS >	MATT	SATIN	VELVET		MATT		SATIN	VELVET

Mix of natural bristles & synthetic bristles



	Round brush	Excellent impregnation and application quality	●	●	●	✓	✓	✓	✓
	Tradition	Naturally flagged, the fibers provide a smooth film and tight finish	●	●	●	✓	✓	✓	✓
	Universal	Solvent-resistant fibers	●	●	●	✓	✓	✓	✓
	Varnish	The combination of bristles and synthetic fibers is suitable for applying water-based paints while ensuring a streak-free finish	●	●	●	✓	✓	✓	✓
	Black bristles		●	●	●	✓	✓	✓	✓

Synthetic fibers



	Worksite	100% nylon fiber	✓	✓		✓	✓		
	Construction range	Staggered and tapered for a streak-free finish	✓	✓		✓	✓		
	Aquasilver	Firm fibers ensure excellent paint release	✓	✓		✓	✓		
	TechniFil	Highly flexible for easy use	✓	✓		✓	✓		
		Easy to clean	✓	✓		✓	✓		

Wood treatment



		TOP synthetic fibers: water-resistant and abrasion-resistant + natural fibers for high-quality absorption and application. Very absorbent.							



Optimized blend of bristle and synthetic

Natural bristles have an affinity with solvent-based paints, offering a smooth film finish. These brushes have a long pull, which, combined with bristle, offers a high absorption capacity for better paint release onto the surface.



Synthetic (100% nylon)

3 different fibers:

- 1 fiber providing lightness and flexibility to the brush for more comfort during application.
- 1 fiber to maintain the brush's shape during use: ensures edging precision.
- 1 fiber ensuring paint release and retention: the brush is aerated to allow the paint to penetrate the fibers.

LACQUERS, DECORATIVE PAINTS				PRIMERS FIXING AGENTS	EXTERIOR PAINTS / WATERPROOFING AND SILOXANE			WOOD TREATMENT		FLOOR PAINTS		MARINE PAINTS		
GLOSS	MATT SATIN	GLOSS	MATT SATIN		THIN COAT	THICK SEMI-THICK COAT	PLIOLITES	GLAZES	SEALANT	THIN	SEMI-THICK	ANTI FOLLING	GELCOAT	

●	●	✓	✓	✓	●	●	✓	✓	✓	✓	✓	●	●
●	●	✓	✓					✓	✓	✓	✓	●	●
●	●	✓	✓					✓	✓	✓	✓		
●	●	✓	✓					✓	✓	✓	✓		
●	●	✓	✓	✓	●	●	✓	✓	✓	✓	✓		

								✓	✓				
								✓	✓				

LAVABRUSH



THE PAINT BRUSH CLEANER

Lavabrush is the patented paint brush cleaning system that saves time, water, and the environment.

Design for professional painters, it prevents microplastics from entering waterways while keeping your tools in peak condition.



MORE P.116

Round pointed sash brush

ALL PAINTS - FINISHING FLAT SURFACES, CORNERS AND MOULDINGS
LONG BRISTLES

Size	Fibre outlet	CODE	
3/0	49 mm	2012530	6
0	55 mm	2012500	6
2	62 mm	2012502	6
4	68 mm	2012504	6
6	74 mm	2012506	6
8	81 mm	2012508	6

Specifications

- Mix of natural & synthetic bristles
- Copper-plated steel ferrule
- Red string collar on sizes 2 to 8
- Varnished wooden handle



Round pointed sash brush

ALL PAINTS - FINISHING FLAT SURFACES, CORNERS AND MOULDINGS
MID LENGTH BRISTLES

Size	Fibre outlet	CODE	
3/0	49 mm	2300530	6
0	49 mm	2300500	6
2	55 mm	2300502	6
4	62 mm	2300504	6
6	68 mm	2300506	6

Specifications

- Mix of natural & synthetic bristles
- Copper-plated steel ferrule
- Varnished wooden handle



Round pointed sash brush

ALL PAINTS - FINISHING OF FLAT SURFACES, CORNERS AND MOULDINGS
SHORT BRISTLES

Size	Fibre outlet	CODE	
3/0	49 mm	2888030	6
0	55 mm	2888000	6
2	55 mm	2888502	6
4	62 mm	2888504	6
6	68 mm	2888506	6
8	74 mm	2888508	6

Specifications

- 100% synthetic layered fibres
- Copper-plated steel ferrule
- Sanded natural wooden handle



Round brush

ALL PAINTS - FINISHING FLAT SURFACES, CORNERS AND MOULDINGS
LONG BRISTLES

Size	Fibre outlet	CODE	
4	57 mm	2301504	6
6	63 mm	2301506	6

Specifications

- Mix of natural & synthetic bristles
- Copper-plated steel ferrule
- Varnished wooden handle



Round brush

SHORT BRISTLES

Size	Fibre outlet	CODE	
4	50 mm	2886504	6
6	57 mm	2886506	6
8	63 mm	2886508	6

Specifications

- 100% Synthetic fibres
- Copper-plated steel ferrule
- Sanded natural wooden handle





Varnish flat brush - Tradition

ALL PAINTS AND VARNISHES
THICK LINE

Size	Fibre outlet	CODE	
40	57 mm	255540	6
50	63 mm	255550	6
60	69 mm	255560	6
70	76 mm	255570	6
80	76 mm	255580	6

Specifications

- Mix of natural & synthetic bristles
- Stainless steel ferrule
- Ergonomic varnished wooden handle



Flat brush for varnishing

ALL PAINTS - FLAT SURFACES
THICK LINE

Size	Fibre outlet	CODE	
20	50 mm	5802020	120
30	50 mm	5802030	120
40	57 mm	5802040	120
50	63 mm	5802050	60
60	63 mm	5802060	60
70	76 mm	5802070	60
80	76 mm	5802080	30

Specifications

- Mix of natural & synthetic bristles
- Nickel plated steel ferrule
- Varnished wooden handle



Flat brush

ALL PAINTS - FLAT SURFACES
THICK LINE

Size	Fibre outlet	CODE	
20	43 mm	252520	6
30	43 mm	252530	6
40	50 mm	252540	6
50	57 mm	252550	6
60	57 mm	252560	6
70	63 mm	252570	6
80	63 mm	252580	6

Specifications

- Mix of natural & synthetic bristles
- Nickel-plated steel ferrule
- Sanded natural wooden handle



Universal flat brush

ALL PAINTS - FLAT SURFACES
MEDIUM LINE

Size	Fibre outlet	CODE	
20	43 mm	250520	6
30	43 mm	250530	6
40	43 mm	250540	6
50	49 mm	250550	6
60	56 mm	250560	6
70	56 mm	250570	6
80	63 mm	250580	6

Specifications

- Mix of natural & synthetic bristles
- Nickel-plated steel ferrule
- Sanded natural wooden handle



Flat brush

ALL PAINTS - FLAT SURFACES
THIN LINE

Size	Fibre outlet	CODE	
15	37 mm	943515	6
20	44 mm	943520	6
25	44 mm	943525	6
30	44 mm	943530	6
35	44 mm	943535	6
40	44 mm	943540	6
50	50 mm	943550	6
60	50 mm	943560	6
70	57 mm	943570	6
80	57 mm	943580	6
90	57 mm	943590	6
100	57 mm	943100	6

Specifications

- Synthetic fibres
- Nickel-plated steel ferrule
- Sanded natural wooden handle



Spalter brush

Specifications

- Bristle and synthetic mix
- Copper plated steel ferrule
- Varnished wooden handle

Size	Fibre outlet	CODE	
100	50 mm	730510	6
120	50 mm	730512	6
140	50 mm	730514	6
160	50 mm	730516	6
200	57 mm	730520	6



Spalter brush

Specifications

- Bristle and synthetic mix
- Copper plated steel ferrule
- Natural wooden handle

Size	Fibre outlet	CODE	
60	50 mm	73060	6
80	50 mm	73080	6
100	50 mm	73100	6
120	50 mm	73120	6
140	50 mm	73140	6
160	50 mm	73160	6
200	50 mm	73200	6



Flat cover brush

ALL PAINTS - HARD TO REACH
AREAS
THIN SERIES

Specifications

- 100% synthetic layered fibres
- Copper-plated steel ferrule
- Varnished wooden handle

Size	Fibre outlet	CODE	
25	50 mm	7947025	6
30	50 mm	7947030	6
35	50 mm	7947035	6
40	50 mm	7947040	6
45	57 mm	7947045	6
60	63 mm	7947060	6



Flat curved brush

THIN SERIES

Specifications

- Synthetic fibers
- Copper-plated steel ferrule
- Sanded natural wooden handle

Size	Fibre outlet	CODE	
25	50 mm	947525	6
30	50 mm	947530	6
35	50 mm	947535	6
40	50 mm	947540	6
45	57 mm	947045	6
60	63 mm	947560	6



Side curved brush

Specifications

- 100% synthetic layered fibres
- Copper-plated steel ferrule
- Sanded natural wooden handle

Size	Fibre outlet	CODE	
30	50 mm	1301530	6
35	50 mm	1301535	6
40	50 mm	1301535	6





Round pointed brush

FINISHING FLAT SURFACES, CORNERS AND MOULDINGS

Specifications

- Mix of natural & synthetic bristles
- White string collar (except size 3/0 and 0)
- Nickel-plated steel ferrule
- Varnished wooden handle

Size	Fibre outlet	CODE	
3/0	49 mm	1305030	6
0	55 mm	1305000	6
2	62 mm	1305002	6
4	68 mm	1305004	6
6	74 mm	1305006	6



Round brush

"L'OUTIL PARFAIT PRO" RANGE

Specifications

- Mix of natural & synthetic bristles
- White twine collar with cap
- Nickel-plated steel ferrule
- Varnished wooden handle

Size	Fibre outlet	CODE	
8	52 mm	5825008	6
10	52 mm	5825010	6
12	59 mm	5825012	6
14	59 mm	5825014	6
16	65 mm	5825016	6
18	71 mm	5825018	6
20	71 mm	5825020	6



Round brush

FINISHING FLAT SURFACES, CORNERS AND MOULDINGS

Specifications

- Mix of natural & synthetic bristles
- With cap - Hermetic
- Nickel-plated steel ferrule
- Wooden handle

Size	Fibre outlet	CODE	
8	52 mm	5824008	6
10	52 mm	5824010	6
12	59 mm	5824012	6
14	59 mm	5824014	6
16	65 mm	5824016	6
18	71 mm	5824018	6
20	71 mm	5824020	6



Round brush

FINISHING FLAT SURFACES, CORNERS AND MOULDINGS

Specifications

- Mix of black bristles and synthetic fibres
- String collar
- Stainless steel ferrule
- Varnished wooden handle

Size	Fibre outlet	CODE	
6	48 mm	2890006	6
8	51 mm	2890008	6
10	54 mm	2890010	6
12	61 mm	2890012	6
14	61 mm	2890014	6
16	67 mm	2890016	6
18	73 mm	2890018	6
20	73 mm	2890020	6
22	79 mm	2890022	6



Flat brush Extra

FLAT SURFACES - ALL PAINTS EXTRA THICK LINE - LONG DRAW

Specifications

- Mix of natural & synthetic bristles
- Stainless steel ferrule
- Ergonomic varnished wooden handle

Size	Fibre outlet	CODE	
30	50 mm	5801030	6
40	57 mm	5801040	6
50	63 mm	5801050	6
60	69 mm	5801060	6
70	69 mm	5801070	6
80	76 mm	5801080	6



Flat brush

FLAT SURFACES - ALL PAINTS THICK LINE

Specifications

- Mix of natural & synthetic bristles
- Nickel-plated steel ferrule
- Varnished wooden handle

Size	Fibre outlet	CODE	
30	50 mm	251030	6
40	57 mm	251040	6
50	63 mm	251050	6
60	63 mm	251060	6
70	76 mm	251070	6
80	76 mm	251080	6



Pointed sash brush AQUASILVER

SPECIALLY FOR ACRYLIC PAINT

Specifications

- 100% synthetic, stepped and tapered
- Stainless steel ferrule
- Varnished wooden handle

Size	Fibre outlet	CODE	
3/0	49 mm	289030	6
0	55 mm	289000	6
2	62 mm	289002	6
4	68 mm	289004	6
6	74 mm	289006	6



AQUASILVER Round brush

SPECIALLY FOR ACRYLIC PAINT

Specifications

- 100% synthetic stepped and tapered
- Stainless steel ferrule
- Varnished wooden handle

Size	Fibre outlet	CODE	
4	68 mm	2887004	6
6	75 mm	2887006	6



AQUASILVER Round brush

SPECIALLY FOR ACRYLIC PAINT
LONG BRISTLES

Specifications

- 100% synthetic stepped and tapered
- Stainless steel ferrule with black cap and string collar
- Varnished wooden handle

Size	Fibre outlet	CODE	
10	52 mm	5816010	6
12	59 mm	5816012	6
14	59 mm	5816014	6
16	65 mm	5816016	6
18	71 mm	5816018	6
20	71 mm	5816020	6



AQUASILVER Flat brush

SPECIAL ACRYLIC PAINT

Specifications

- 100% synthetic
- Stainless steel ferrule
- Ergonomic varnished wooden handle

Size	Fibre outlet	CODE	
30	50 mm	288030	6
40	57 mm	288040	6
50	63 mm	288050	6
60	69 mm	288060	6
70	69 mm	288070	6
80	76 mm	288080	6



Flat brush

SPECIAL ACRYLIC PAINT

Specifications

- 100% synthetic
- Ergonomic varnished wooden handle

Size	Fibre outlet	CODE	
30	49 mm	1815030	6
40	56 mm	1815040	6
50	62 mm	1815050	6
60	68 mm	1815060	6
70	68 mm	1815070	6





Deco brush AQUASILVER

ACRYLIC PAINT - ANGULAR FOR FINISHING CORNERS AND MOULDINGS - SHORT HANDLE THICK SERIES - LONG AND SOFT BRISTLES SHORT HANDLE

Size	Fibre outlet	CODE	
50	59 mm	291050	6



Specifications

- 100% synthetic
- Stainless steel ferrule
- Ergonomic varnished wooden handle

Sash brush AQUASILVER

ACRYLIC PAINT - ANGULAR FOR FINISHING CORNERS AND MOULDINGS - LONG HANDLE THICK SERIE - LONG AND SOFT BRISTLES

Size	Fibre outlet	CODE	
50	59 mm	292050	6
73	75 mm	292075	6



Specifications

- 100% synthetic
- Stainless steel ferrule
- Ergonomic varnished wooden handle

Varnish brush AQUASILVER

SEALANT AND ACRYLIC LACQUERS FLAT SURFACES EXCELLENT RESILIENCE NO STRINGING EFFECT WHEN REMOVED

Size	Fibre outlet	CODE	
80	57 mm	2347080	6
100	57 mm	2347100	6
140	57 mm	2347140	6



Specifications

- 100% synthetic
- Stainless steel ferrule
- Varnished wooden handle

Flat curved brush

SPECIAL ACRYLIC PAINT - DIFFICULT TO ACCESS AREAS EXCELLENT RESILIENCE THICK SERIE

Size	Fibre outlet	CODE	
30	49 mm	290030	6
40	49 mm	290040	6
60	57 mm	290060	6



Specifications

- 100% synthetic
- Stainless steel ferrule
- Varnished wooden handle

TECHNIFIL

NEW

Blend of fibers for greater precision, retention, and paint release onto the surface.
Optimal shape retention of the brush during use.
More comfort during application.
Combination of 3 synthetic fibers.

Stainless steel ferrule
Prevents oxidation caused by water-based paints.

Application comfort
Lightness and flexibility of the fiber.

Paint release & retention
Smooth finish without streaks.

Twine binding
Maintains the shape for edging and makes cleaning easier.



Round pointed brush

**SPECIAL WATER-BASED PAINT
SUITABLE FOR ALL PAINTS
LONG BRISTLES**

Specifications

- 100% synthetic
- String collar
- Stainless steel ferrule
- Varnished wooden handle

Size	Fibre outlet	CODE	
3/0	49 mm	4111030	6
0	55 mm	4111000	6
2	62 mm	4111002	6
4	74 mm	4111004	6
6	81 mm	4111006	6



TechniFil flat brush

**SPECIAL WATER-BASED PAINT
SUITABLE FOR ALL PAINTS
LONG BRISTLES**

Specifications

- 100% synthetic
- Mounted on flower
- Stainless steel ferrule
- Varnished wooden handle

Size	Fibre outlet	CODE	
30	49 mm	4112030	6
40	56 mm	4112040	6
50	62 mm	4112050	6
60	68 mm	4112060	6



Technifil Flat curved brush

**SPECIAL WATER-BASED PAINT
SUITABLE FOR ALL PAINTS
LONG BRISTLES**

Specifications

- 100% synthetic
- Stainless steel ferrule
- Varnished wooden handle

Size	Fibre outlet	CODE	
30	49 mm	4113030	6
40	49 mm	4113040	6



TechniFil Varnish brush

**WATER-BASED SEALANT AND
LACQUER
SUITABLE FOR ALL PAINTS**

Specifications

- 100% synthetic
- Flange mounted
- Varnished wooden handle

Size	Fibre outlet	CODE	
100	57 mm	4114100	6
140	57 mm	4114140	6





Round pointed brush Wood treatment

MEDIUM-LONG BRISTLES

Specifications

- Mix of natural & synthetic bristles
- Nickel-plated steel ferrule
- Varnished wooden handle

Size	Fibre outlet	CODE	
3/0	49 mm	2871030	6
0	49 mm	2871000	6
2	55 mm	2871002	6
4	62 mm	2871004	6



Flat brush

THICK LINE

Specifications

- Mix of natural & synthetic bristles
- Nickel-plated steel ferrule
- Varnished wooden handle

Size	Fibre outlet	CODE	
20	49 mm	261020	6
30	49 mm	261030	6
40	49 mm	261040	6
50	56 mm	261050	6
60	62 mm	261060	6
70	68 mm	261070	6
80	76 mm	261080	6



Flat curved brush

HARD TO REACH AREAS

Specifications

-

Size	Fibre outlet	CODE	
25	44 mm	7291025	6
35	50 mm	7291035	6



Flat curved brush

EXTRA THICK SERIE

Specifications

- Mix of natural & synthetic grey bristles
- Stainless steel ferrule
- Sanded natural wooden handle

Size	Fibre outlet	CODE	
70	69 mm	55070	6





Acrylic flat brush

FOR ACRYLIC PAINT
THICK LINE

Size	Fibre outlet	CODE	
20	68 mm	1803520	6
30	49 mm	1803530	6
40	49 mm	1803540	6
50	56 mm	1803550	6
60	62 mm	1803560	6
70	68 mm	1803570	6
80	68 mm	1803580	6

Specifications

- 100 % Synthetic bristles
- Nickel-plated steel ferrule
- Varnished wooden handle



Universal flat brush

ALL PURPOSE BRUSH
THICK LINE

Size	Fibre outlet	CODE	
20	43 mm	2376020	6
30	43 mm	2376030	6
40	43 mm	2376040	6
50	49 mm	2376050	6
60	56 mm	2376060	6
70	56 mm	2376070	6
80	63 mm	2376080	6

Specifications

- 100% synthetic bristles
- Nickel-plated steel ferrule
- Varnished polypro handle



Acrylic flat brush

FOR ACRYLIC PAINT
THICK LINE

Size	Fibre outlet	CODE	
20	49 mm	2378020	6
30	49 mm	2378030	6
40	49 mm	2378040	6
50	49 mm	2378050	6
60	57 mm	2378060	6
70	57 mm	2378070	6
80	63 mm	2378080	6

Specifications

- 100% synthetic, stepped
- Nickel-plated steel ferrule
- Varnished polypro handle



Flat brush

MEDIUM LINE

Size	Fibre outlet	CODE	
20	43 mm	2348020	120
30	43 mm	2348030	120
40	43 mm	2348040	120
50	49 mm	2348050	60
60	56 mm	2348060	60
70	56 mm	2348070	60
80	63 mm	2348080	30

Specifications

- Mix of natural & synthetic bristles
- Nickel-plated steel ferrule
- Varnished polypro handle



Universal flat brush

ALL PAINTS

Size	Fibre outlet	CODE	
20	44 mm	2308020	6
30	44 mm	2308030	6
40	44 mm	2308040	6
50	50 mm	2308050	6
60	57 mm	2308060	6
70	57 mm	2308070	6
80	63 mm	2308080	6

Specifications

- Mix of natural & synthetic bristles
- Nickel-plated steel ferrule
- Polypro handle



Wood treatment flat brush

FOR GLAZE, VARNISH AND WOOD
TREATMENT
THIN LINE

Size	Fibre outlet	CODE	
20	43 mm	2380020	6
30	43 mm	2380030	6
40	43 mm	2380040	6
50	49 mm	2380050	6
60	56 mm	2380060	6
70	56 mm	2380070	6
80	62 mm	2380080	6

Specifications

- Mix of natural & polyester bristles
- Nickel-plated steel ferrule
- Varnished polypro handle





Flat brush

**FOR THE APPLICATION OF VARNISH OR SATURATOR
PAINT BRUSH - PROFESSIONAL MOUNTING
LONG BRISTLES**

Size	Fibre outlet	CODE	
100	60 mm	953500	6
120	68 mm	953520	6
140	68 mm	953550	6

Specifications

- Extra pure white silk
- Hanging hole and double metal holding clip
- Curved varnished wooden handle



Flat brush

**PAINT BRUSH - FOR ALL PAINTS
LONG BRISTLES**

Size	Fibre outlet	CODE	
100	59 mm	952500	6
120	62 mm	952520	6

Specifications

- Blend of white bristles and polyester
- Plastic handle with holding clip



Flat brush

LONG BRISTLES

Size	Fibre outlet	CODE	
100	30 mm	447100	6
120	30 mm	447120	6

Specifications

- Mix of natural & synthetic bristles
- Plastic handle with holding clip



Angled woodstain brush

**SPECIAL WOODSTAIN AND WOOD TREATMENT
IDEAL FOR DECKING AND CLADDING**

Size	Fibre outlet	CODE	
120	60 mm	2847120	10
With pole			
120	60 mm	2848120	10

Specifications

- Optimised blend of selected synthetic fibre
- Polypropylene one-piece drill mount
- Tin plated ferrule
- Dimensions: 120 x 30 mm



INDEX



NEW CODE				DELETED CODE				REPLACED BY			
CODE		EAN Code	Page	CODE		EAN Code	Page	CODE		EAN Code	Page
8898	1	3289550088981	28	252530	6	3289552525309	125	455200	3	3289554552006	82
55070	6	3340530007986	131	252540	6	3289552525408	125	455220	3	3289554552204	82
73060	6	3340530008112	126	252550	6	3289552525507	125	455240	3	3289554552402	82
73080	6	3340530008129	126	252560	6	3289552525606	125	455260	3	3289554552600	82
73100	6	3340530008136	126	252570	6	3289552525705	125	456160	3	3289554561602	82
73120	6	3340530008143	126	252580	6	3289552525804	125	456180	3	3289554561800	82
73140	6	3340530008150	126	255540	6	3289552555405	125	456200	3	3289554562005	82
73160	6	3340530008167	126	255550	6	3289552555504	125	456220	3	3289554562203	82
73200	6	3340530008181	126	255560	6	3289552555603	125	457120	3	3289554571205	82
80117	1	3289550801177	38	255570	6	3289552555702	125	457140	3	3289554571403	82
80321	2	3289550803218	34	255580	6	3289550500292	125	457160	3	3289554571601	82
80322	2	3289550803225	34	261020	6	3289552610203	131	457180	3	3289554571809	82
80374	1	3289550803744	30	261030	6	3289552610302	131	458140	3	3289554581402	82
80401	1	3289558040103	23, 32	261040	6	3289552610401	131	458160	3	3289554581600	82
80426	1	3289558042600	63	261050	6	3289552610500	131	461118		3289554611185	
80427	1	3289558042701	31	261060	6	3289552610609	131	461180		3289554611802	
80428	1	3289558042800	31	261070	6	3289552610708	131	466000	1	3289554660008	78
80474	4	3289550804741	53	261080	6	3289552610807	131	475002	5	3289554750020	58
80488	1	3289550804888	20, 36	288030	6	3289552880309	128	475003	5	3289554750037	58
80497	1	3289550804970		288040	6	3289552880408	128	475004	5	3289554750044	58
80506	1	3289550805069	30	288050	6	3289552880507	128	475005	5	3289554750051	58
80508		Replaced by 80625		288060	6	3289552880606	128	475006	5	3289554750068	58
80560		3289550805601		288070	6	3289552880705	128	475007	5	3289554750075	58
80606	1	3289550806066	27	288080	6	3289552880804	128	475008	5	3289554750082	58
80607	1	3289550806073	18, 30	289000	6	3289552890001	128	475010	5	3289554750105	58
80617	4	3289550806172	28	289002	6	3289552890025	128	475012	5	3289554750129	58
80622	1	3289550806226	31	289004	6	3289552890049	128	478001	5	3289554780010	58
80623	1	3289550806233	49	289006	6	3289552890605	128	478002	5	3289554780027	58
80624	1	3289550806240	14, 27	289030	6	3289552890308	128	478003	5	3289554780034	58
80625	1	3289550806257	16, 27	290030	6	3289552900304	129	478004	5	3289554780041	58
80636	1	3289550806363	19, 31	290040	6	3289552900403	129	478005	5	3289554780058	58
80660	1	3289550806608	21, 33	290060	6	3289552900601	129	478006	5	3289554780065	58
80806	1		71	291050	6	3289552910501	129	478007	5	3289554780072	58
80810	1		74	292050	6	3289552920500	129	478008	5	3289554780089	58
80811	1		74	292075	6	3289552920753	129	478010	5	3289554780102	58
80813	1		74	313000	2	3289553130007	35	479002	5	3289554790026	58
102000	5	3289551020010	120	318000	1	3226631045808	120	479004	5	3289554790040	58
125000	1	3289551250004	80	340008		3289553400087		479006	5	3289554790064	58
126000	1	3289551260003		360006	1	3289553600067	60	479008	5	3289554790088	58
152000	6	3289550506898	43	360008	1	3289553600081	60	479010	5	3289554790101	58
156000		0091511500455		364000	1	3289553640001	59	479012	5	3289554790125	58
158000	10	3289550506904	43	365000	5	3289553650000	60	481002		3289554810021	
161000		091511200478		374000	1	3289553745300	60	481003		3289554810038	
230000	5	3289552300005	60	394000	5	3289553940101		481004		3289554810045	
232070	6	3289550506515	134	400008		3289559400081		481005		3289554810052	
232100	6	3289552321000	134	414000	1	3289554140005	65	481006		3289554810069	
241025	2	3289552410254	29	422003	1	3289554220035	65	481007			
241035	2	3289552410353	29	422006	1	3289554220066	65	481008		3289554810083	
241045	2	3289552410452	29	422008	1	3289554220080	65	481010		3289554810106	
241060	2	3289552410605	29	422010	1	3289554220103	65	481012		3289554810120	
241080	1	3289552410803	29	422012	1	3289554220127	65	486000	5	3289554860002	61
241100	1	3289552411008	29	440012	1	3289554400123	57	487000	5	3289554870001	61
241120	1	3289552411206	29	440015	1	3289551599134	57	501002	5	3289555010024	56
250520	6	3289552505202	125	440018	1	3289554400185	57	501004	5	3289555010048	56
250530	6	3289552505301	125	440021	1	3289554400215	57	501006	5	3289555010062	56
250540	6	3289552505400	125	440023	1	3289554400239	57	501008	5	3289555010086	56
250550	6	3289552505054	125	440025	1	3289554400253	57	501010	5	3289555010109	56
250560	6	3289552505608	125	440030	1	3289554400307	57	502002	5	3289555020023	56
250570	6	3289552505707	125	442012	5	3289554420121	57	502003	5	3289555020030	56
250580	6	3289552505806	125	442015	5	3289554420152	57	502004	5	3289555020047	56
251020		3289552510206		442018	5	3289554420183	57	502005	5	3289555020054	56
251030	6	3289552510305	127	442021	5	3289554420213	57	502006	5	3289555020061	56
251040	6	3289552510404	127	442025	5	3289554420251	57	502007	5	3289555020078	56
251050	6	3289552510503	127	442030	5	3289554420305	57	502008	5	3289555020085	56
251060	6	3289552510602	127	447100	6	3289550506768	135	502010	5	3289555020108	56
251070	6	3289552510701	127	447120	6	3289550506775	135	505002	5	3289555050020	54
251080	6	3289552510800	127	455160	3	3289554551603	82	505004	5	3289555050044	54
252520	6	3289552525200	125	455180	3	3289554551801	82	505006	5	3289555050068	54



NEW CODE

DELETED CODE

REPLACED BY

139

CODE		EAN Code	Page
505008	5	3289555050082	54
505010	5	3289555050105	54
505012	5	3289555050129	54
505015	5	3289555050150	54
505025	5	3289555050259	54
507000	5	3289555070004	55
510002	5	3289555100022	57
510003	5	3289555100039	57
510004	5	3289555100046	57
510005	5	3289555100053	57
510006	5	3289555100060	57
510007	5	3289555100077	57
510008	5	3289555100084	57
510010	5	3289555100107	57
514004	5	3289551199204	54
514006	5	3289551199211	54
514008	5	3289551199228	54
514010	5	3289551199235	54
514012	5	3289551199242	54
514015	5	3289551199259	54
515000	1	3289555150126	119
518000	5	3289555180000	59
520001	5	3289555200012	56
520002	5	3289555200029	56
520003	5	3289555200036	56
520004	5	3289555200043	56
520005	5	3289555200050	56
520006	5	3289555200067	56
520007	5	3289555200074	56
520008	5	3289555200081	56
520010	5	3289555200104	56
520012	5	3289555200128	56
522000	5	3289555220003	61
523000	5	3289555230002	61
525000	5	3289555250000	61
527000	5	3289555270008	61
529000	5	3289555290006	61
531060	1	3289555310605	64
532007	5	3289555320079	59, 77
532010	5	3289555320109	59, 77
533000	5	3289555330009	59
534050	1	3289555340503	64
534060	1	3289555340602	64
535000	1	3289555350007	77
536000	5	3289555360000	61
537035	1	3289555370357	64
537050	1	3289555370500	64
537060	1	3289555370609	64
540000	1	3289555400009	119
541002	2	3289555410022	28
541004	2	3289555410046	28
541006	2	3289555410060	28
541008	2	3289555410084	28
541010	2	3289555410107	28
541012	2	3289555410121	28
541015	2	3289555410152	28
541025	2	3289555410251	28
541035	2	3289555410350	28
541045	2	3289555410459	28
541060	2	3289555410602	28
541080	1	3289555410800	28
541100	1	3289555411005	28
541120	1	3289555411203	28
542000	10	3289555420007	119
545008	5	3289555450080	62
545010	5	3289555450103	62
545012	5	3289555450127	62
545014	5	3289555450141	62

CODE		EAN Code	Page
545016	5	3289555450165	62
545018	5	3289555450189	62
545020	5	3289555450202	62
545022	5	3289555450226	62
545024	5	3289555450240	62
545030	5	3289555450301	62
545112	5	3289555451124	62
545114	5	3289555451148	62
545116	5	3289555451162	62
545118	5	3289555451186	62
545120	5	3289555451209	62
545122	5	3289555451223	62
545124	5	3289555451247	62
546010	5	3289555460102	63
546012	5	3289555460126	63
546014	5	3289555460140	63
546016	5	3289555460164	63
546018	5	3289555460188	63
546020	5	3289555460201	63
546022	5	3289555460225	63
546024	5	3289555460249	63
546030	5	3289555460300	63
546312	5	3289551499960	63
546314	5	3289551499977	63
546316	5	3289551499984	63
546318	5	3289551499991	63
546320	5	3289551454600	63
546322	5	3289551454648	63
546324	5	3289551454624	63
547000	1	3289555470002	119
549020	1	3289555490208	64
549035	1	3289555490352	64
549050	1	3289555490505	64
549060	1	3289555490604	64
550014	1	3289555500143	52
550018	1	3289555500181	52
550024	1	3289555500242	52
550030	1	3289555500303	52
550040	1	3289555500402	52
550050	1	3289555500501	52
550065	1	3289555500655	52
550090	1	3289555500907	52
550110	1	3289555501102	52
553000	5	3289555530249	
554000	5	3289555540248	73
555008	5	3289555550087	62
555010	5	3289555550100	62
555012	5	3289555550124	62
555014	5	3289555550148	62
555016	5	3289555550162	62
555018	5	3289555550186	62
555020	5	3289555550209	62
555022	5	3289555550223	62
555024	5	3289555550247	62
555030	5	3289555550308	62
555310		3289551499762	
555314		3289551499786	
555316		3289551499793	
555318		3289551499809	
555320		3289551499816	
555322		3289551499823	
555324		3289551499830	
555330		3289551499847	
559010	5	3289555590106	63
559012	5	3289555590120	63
559014	5	3289555590144	63
559016	5	3289555590168	63
559018	5	3289555590182	63

CODE		EAN Code	Page
559020	5	3289555590205	63
559022	5	3289555590229	63
559024	5	3289555590243	63
559030	5	3289555590304	63
560012	5	3289555600126	73
560020	5	3289555600201	73
560112	5	3289555601123	73
560120	5	3289555601208	73
560130	5	3289555601307	73
560220	5	3289555602205	73
560230	5	3289555602304	73
560320	5	3289555603202	73
561120	5	3289555611207	73
561220	5	3289555612204	73
561230	5	3289555612303	73
561312	5	3289555613126	73
561320	5	3289555613201	73
561330	5	3289555613300	73
562112	5	3289555621121	75
562120	5	3289555621206	75
562130	5	3289555621305	75
562220	5	3289555622203	75
562230	5	3289555622302	75
562308	5	3289555623088	75
562312	5	3289555623125	75
562320	5	3289555623200	75
562330	5	3289555623309	75
562420	5	3289555624207	75
562430	5	3289555624306	75
563020	5	3289555630208	75
563030	5	3289555630307	75
566030	2	3289555660304	
566065			
566100			
568010	1	3289555680104	52
568018	1	3289555680180	52
568024	1	3289555680241	52
568030	1	3289555680302	52
568040	1	3289555680401	52
568050	1	3289555680500	52
568065	1	3289555680609	52
568090	1	3289555680906	52
570014	2	3289555700147	52
570018	2	3289555700185	52
570024	2	3289555700246	52
570030	2	3289555700307	52
570040	2	3289555700406	52
570050	2	3289555700505	52
570065			
570090			
574030	2	3289555740303	52
574060	2	3289555740600	52
574065			
574080	2	3289555740808	52
574090			
574100	2	3289555741003	52
577000	1	3289555770003	71
582000	10	3289555820005	29
585070	1	3289555850705	76
604002	5	3289556040020	57
604003	5	3289556040037	57
604004	5	3289556040044	57
604005	5	3289556040051	57
604006	5	3289556040068	57
604007	5	3289556040075	57
604008	5	3289556040082	57
604009	5	3289556040099	57
604010	5	3289556040105	57

CODE		EAN Code	Page
604012	5	3289556040129	57
612000	1	3289556120005	50, 78
615000	1	3289556150002	48, 72
616006	1	3289556160063	48, 72
616008	1	3289556160087	48, 72
616010	1	3289556160100	48, 72
618000	1	3289556180009	65
619006	1	3289550002574	72
619008	1	3289550002581	72
619010	1	3289550002598	72
620120	1	3289559996065	83
620122	1	3289559996072	83
620124	1	3289559996089	83
620126	1	3289559996096	83
620128		3289559996478	
620200	1	3289551899142	83
620220	1	3289551899159	83
620240	1	3289556202404	83
620260	1	3289556202602	83
620280	1	3289551899166	83
623000		3289556230001	
624000		3289556240000	
627000		3289556270007	
627100		3289556271189	
631000	1	3289556310000	65
632035	1	3289556320351	79
632045	1	3289556320450	79
632060	1	3289556320603	79
633045	1	3289556330459	79
633060	1	3289556330602	79
634008	2	3289556340083	76
634015	2	3289556340151	76
636140	3	3289556361408	80
636160	3	3289556361606	80
636180	3	3289556361804	80
638000		3289556381864	
646112	1	3289559996133	83
646114	1	3289559996140	83
646120	1	3289556461207	83
646140	1	3289556461405	83
647118	1	3289559995549	83
647120	1	3289559995556	83
647122	1	3289559995563	83
647124	1	3289559995570	83
647126	1	3289559995587	83
647128	1	3289559995594	83
647180	1	3289551899173	83
647200	1	3289556472005	83
647220	1	3289556472203	83
647240	1	3289556472401	83
647260	1	3289556472609	83
647280	1	3289556472807	83
649106	1	3289559995600	83
649107	1	3289559995617	83
649108	1	3289559995624	83
649109	1	3289559995631	83
649127	1	3289551899111	83
649152	1	3289551899128	83
649165	1	3289556491655	83
649178	1	3289556491785	83
649190	1	3289556491907	83
649200	1	3289556492003	83
649216	1	3289556492164	83
649230	1	3289551899135	83
653160	3	3289556531603	80
653180	3	3289556531801	80
653200	3	3289556532006	80
653220	3	3289556532204	80

NEW CODE

DELETED CODE

REPLACED BY

CODE		EAN Code	Page
653240	3	3289556532402	80
654180	3	3289556541800	80
654200	3	3289556542005	80
655200		3289556552004	
656200		3289556562003	
658110	1	3289550121800	66
658112	1	3289550121114	66
658175	1	3289556582759	66
659008	1	3289556590082	81
659010	1	3289556590105	81
659012	1	3289556590129	81
659014	1	3289556590143	
662140		3289556621403	
662160		3289556621601	
664160		3289556641609	
684180	6	3289556841801	96
697000	5	3289556970006	78
698550	1	3289556985505	120
699010	1	3289556990103	81
699012	1	3289556990127	
728508	6	3289557285086	134
728510	6	3289557285109	134
728512	6	3289557285123	134
728514	6	3289557285147	134
728520	6	3289557285208	134
730510	6	3289557305104	126
730512	6	3289557305128	126
730514	6	3289557305142	126
730516	6	3289557305166	126
730520	6	3289557305203	126
763024	2	3289557630244	26
764025	2	3289557640250	29, 50
764035	2	3289557640359	29, 50
764045	2	3289557640458	29, 50
764060	2	3289557640601	29, 50
764080	1	3289557640809	29, 50
764100	1	3289557641004	29, 50
769000	10	3289557695007	118
769250	10	3289550502401	118
789000	10	3289557890006	118
825000	1	3289558250007	42
826000	1	3289558260006	42
828180	6	3289550828181	101
828250	6	3289550828259	101
829180	6	3289550829188	106
829250	6	3289558292502	106
856000	10	3289558560007	120
857180	6	3289550503590	96
857250	6	3289550503606	96
860180	6	3289550503583	93
862180	6	3289558621807	94
863180	6		104
863250	6	3289558632506	104
866180	6	3289558661803	99
866220	6	3289558662206	99
866250	6	3289558662503	99
867180	6	3289550503644	
868180	6	3289550503743	106
868250	6	3289550503736	106
868500	6	3289558685007	110
869180	6	3289550503712	105
869250	6	3289550503705	105
870580	6	3289558705804	102
871180	6	3289558711805	102
871220	6	3289558712208	102
871250	6	3289558712505	102
871500	6	3289558715001	110
872180	6	3289558721804	103

CODE		EAN Code	Page
872250	6	3289558722504	103, 110
872500	6	3289558725000	110
873180	6	3289558731803	100
873250	6	3289558732503	100
875180	6	3289558751801	92
876180	6	3289550508823	92
877180	6	3289550508922	104
878180	6	3289550508939	
879150	1	3289558791500	76
879300	1	3289558793009	76
880180	6	3289558801803	97
880220	6	3289558802206	97
880250	6	3289558802503	97
882180	6	3289558821801	98
887180	24	3289558871806	108
889180	6	3289558891804	96
889250	6	3289558892504	96
891520	6	3289558915203	136
891530	6	3289558915302	136
891540	6	3289558915401	136
891550	6	3289558915500	136
891560	6	3289558915609	136
892530	6	3289558925301	134
892540	6	3289558925400	134
892560	6	3289558925608	134
898180	120	3289558981802	106
898250	60	3289558982502	106
900550	6	3289559005507	107
900580	6	3289550018476	107
901015	5	3289559010150	65
901020	5	3289559010204	65
901030	5	3289559010303	65
902015	5	3289559020159	65
902020	5	3289559020203	65
902030	5	3289559996515	65
910029	1	3289559100295	79
910129	1	3289551699452	79
929000	10	3289559290101	43
931000	20	3289559310106	43
941005	12	3289559410059	134
941006	12	3289559410066	134
941007	12	3289559410073	134
943100	6	3289550500735	125
943515	6	3289559435151	125
943520	6	3289559435205	125
943525	6	3289559435250	125
943530	6	3289559435304	125
943535	6	3289559435359	125
943540	6	3289559435403	125
943550	6	3289559435502	125
943560	6	3289559435601	125
943570	6	3289559435700	125
943580	6	3289559435809	125
943590	6	3289559435908	125
946180	10	3289559461808	109
947045	6	3289559475508	126
947525	6	3289559475256	126
947530	6	3289559475300	126
947535	6	3289559475355	126
947540	6	3289559475409	126
947560	6	3289559475607	126
949514	3	3289559495148	136
952500	6	3289559525005	135
952520	6	3289559525203	135
953500	6	3289559535004	135
953520	6	3289559535202	135
953550	6	3289559535509	135
960580	10	3289559601808	109



NEW CODE

DELETED CODE

REPLACED BY

CODE		EAN Code	Page
961580	10	3289559615805	109
962580	10	3289559625804	109
963580	10	3289559635803	109
964580	10	3289559645802	109
965180	6	3289559651803	105
965250	6	3289559652503	105
966180	10	3289559661802	109
967080	6	3289559670804	112
967220	6	3289559672204	112
967550	6	3289559675502	112
967580	6	3289559675809	112
968080	6	3289550506119	
968550	6	3289559685501	
968580	6	3289559685808	
969080	6	3289550506133	98
969550	6	3289559695500	98
969580	6	3289559695807	98
970080	6	3289550506171	98
970550	6	3289559705506	98
970580	6	3289559705803	98
972250	6	3289550503750	101
972500	6	3289559725252	110
972580	6	3289550503767	101
973220	6	3289559732205	105
973550	6	3289559735503	105
973580	6	3289559731802	105
974550	6	3289559745502	
974580	6	3289559745809	
975580	6	3289559755808	93
976080		3289550506096	
976580	6	3289559761809	95
980550	6	3289559805503	120
980580	6	3289559801802	120
984180	6	3289550508946	97
984220	6	3289559842201	97
984250	6	3289559842508	97
986180	10	3289559861806	109
986250	10	3289559862506	109
987080	5	3289559870808	24
987180	5	3289559871805	24
987220	5	3289559872208	24
987250	5	3289559872505	24
987300	5	3289559873007	24
987400	5	3289559874004	24
988180	6	3289550505440	103
988250	6	3289550508953	103
992019	6	3289550503668	113
992529	6	3289559925294	113
992540	6	3289559925409	113
992555	6	3289559925553	113
1176004	1	3289551176403	60
1176006	1	3289551176069	60
1190000	1	3289551190003	60
1202000	1	3289551202003	44
1210000	1	3289551210015	44
1212000	1	3289551212002	44
1213000	1	3289551213009	45
1214000	1	3289551214006	45
1273180	24	3289550507642	108
1273250	18	3289551273256	108
1277180	24	3289550507659	108
1277550	18	3289551277551	108
1279180	24	3289551279180	108
1301530	6	3289551301300	126
1301535	6	3289551301539	126
1301540	6	3289551301409	126
1305000	6	3289551305001	127
1305002	6	3289551305025	127

CODE		EAN Code	Page
1305004	6	3289551305049	127
1305006	6	3289551305063	127
1305030	6	3289551305308	127
1307504	6	3289551307043	136
1307506	6	3289551307067	136
1320500	6	3289551320509	110
1320550	6	3289551320257	110
1321500		3289551321506	
1322500	6	3289551322503	110
1323500	1	3289551323500	111
1324000	1	3289551324002	24, 111
1325500	6	3289551325504	110
1328500		3289551328505	
1328550		3289551328253	
1330580	6	3289551330188	
1344040		3289551344352	
1344070		3289551344703	
1344100	1	3289551344109	114
1348070	4	3289551348077	71, 115
1348100	4	3289551348107	71, 115
1348150	4	3289551348152	71, 115
1349000	1	3289551349005	34
1350000	1	3289551350001	34
1357000	1	3289551357000	35
1360000	1	3289551360000	35
1367000	1	3289551367009	34
1375025	1	3289551375257	64
1375030	1	3289551375301	64
1375035	1	3289551375356	64
1378000	1	3289551378203	32, 40
1378001	1	3289551378012	32, 40
1382000	1	3289551382002	35
1389000	1	3289551389001	35
1443000	1	3289551443000	119
1473300	1	3289552197025	65
1474006	1	3289551474066	65
1474008	1	3289551474080	65
1474010	1	3289551474103	65
1474012	1	3289551474127	65
1476000	10	3289551476008	114
1476070	10	3289551476077	114
1476150	10	3289551476152	114
1480070	4	3289551480074	115
1482100	4	3289551482207	34
1483070	10	3289551483709	114
1483100	10	3289551483105	114
1513000	1	3289551513000	43
1531060	50	3289551531066	49
1534035	1	3289551534357	49
1534050	1	3289551534050	49
1534060	1	3289551534067	49
1540140		3289551540143	
1540160	12	3289559999509	86
1540180	12	3289550003793	86
1540200	12	3289550003809	86
1540220	12	3289550003816	86
1540240		3289551540242	
1594200	6	3289551594207	114
1603000	1	3289551603008	
1620038	12	3289551620388	117
1626000		3289551626007	
1627036	5	3289551627363	38
1673000	1	3289551673001	50, 78
1677000	1	3289550502135	69
1686000	5	3289551686001	77
1686010	5	3289551686100	77
1713035	1	3289551713356	67
1714028	1	3289551714285	67

CODE		EAN Code	Page
1714035	1	3289551714353	67
1715008		3289551715084	
1715411		3289551715114	
1715812		3289551715121	
1716008	1	3289551716081	69
1716411	1	3289551716111	69
1716812	1	3289551716128	69
1717000	1	3289551717002	39, 68
1718028	1	3289551718283	39, 67
1718035	1	3289551718351	39, 67
1719030	1	3289551719303	67
1719035	1	3289551719358	67
1724036	1	3289551724369	69
1725030	1	3289551725304	39, 67
1725035	1	3289551725359	39, 67
1725040	1	3289551725403	39, 67
1725045	1	3289551725458	39, 67
1726030	1	3289551726301	39, 67
1726035	1	3289551726356	39, 67
1726040	1	3289551726400	39, 67
1726045	1	3289551726455	39, 67
1727021	1	3289551727216	69
1728022	1	3289551728251	69
1729024	1	3289551729241	69
1734027	1	3289551734276	69
1766070	4	3289551766079	24, 41, 115
1766100	6	3289551766109	24, 32, 41, 115
1768080	6	3289551768080	32
1769000	4	3289551769018	26
1770040	1	3289551770045	24, 112
1770080	1	3289551770083	24, 112
1770180	1	3289551770182	24, 112
1770220	1	3289551770229	24, 112
1770250	1	3289551770250	24, 112
1771000	1	3289551771004	
1776000	1	3289551776009	45
1777000	1	3289551777006	44
1792000	10	3289551792009	119
1803520	6	3289551803200	133
1803530	6	3289551803309	133
1803540	6	3289551803408	133
1803550	6	3289551803507	133
1803560	6	3289551803606	133
1803570	6	3289551803705	133
1803580	6	3289551803804	133
1807000		091511200188	
1808000		091511500301	
1815030	6	3289551815302	128
1815040	6	3289551815401	128
1815050	6	3289551815500	128
1815060	6	3289551815609	128
1815070	6	3289551815708	128
1837180		3289551837182	
1866000	1	3289551866007	75
1867035	1	3289551867356	79
1867045	1	3289551867455	79
1867060	1	3289551867608	79
1880500	1	3289551880508	111
1880550	1	3289551880553	111
1880580	1	3289551880188	111
1882180	1	3289551882182	111
1882250	1	3289551882250	111
1882500	1	3289551882502	111
1887180		3289551887187	
1902118		3289551902118	
1902180	1	3289551902187	85
1903000	1	3289551903009	85
1903100	1	3289559995679	85

NEW CODE				DELETED CODE				REPLACED BY			
CODE		EAN Code	Page	CODE		EAN Code	Page	CODE		EAN Code	Page
1903118		3289559031186		2096007	1	3289552096076	82	2338008	1	3289551699674	70
1903180	1	3289551799718	85	2096008	1	3289552096083	82	2338411	1	3289551699681	70
1904000	1	3289551904006	85	2096106	1	3289551899180	82	2338812	1	3289551699698	70
1904100		3289551799916		2096107	1	3289551899197	82	2347080	6	3289552347802	129
1905000	1	3289551905003	84	2096108	1	3289551899203	82	2347100	6	3289552347109	129
1905100	1	3289551905102	84	2098000	1	3289552098001	82	2347140	6	3289552347147	129
1906118		3289559995686		2098100	1	3289551899258	82	2348020	120	3289552348205	133
1906120	1	3289551899104	84	2099000	1	3289552099008	82	2348030	120	3289552348304	133
1906180		3289551906185		2099100	1	3289551899265	82	2348040	120	3289552348403	133
1906200	1	3289551906208	84	2100160	3	3289552100162	81	2348050	60	3289552348502	133
1907112		3289559071120		2100180	3	3289552100186	81	2348060	60	3289552348601	133
1907114		3289559071144		2100200	3	3289552100209	81	2348070	60	3289552348700	133
1907116		3289559071168		2100220	3	3289552100223	81	2348080	30	3289552348809	133
1907118		3289559071182		2100240	3	3289552100247	81	2356000	1	3289552356002	67
1907120	1	3289559071205	85	2101160	3	3289552101169	81	2357000	1	3289552357009	67
1907140	1	3289551907144	85	2101180	3	3289552101183	81	2358008	1	3289552358082	70
1907160	1	3289551907168	85	2101200	3	3289552101206	81	2358411	1	3289552358112	70
1907180	1	3289551907182	85	2101220	3	3289552101220	81	2376020	6	3289552376024	133
1907200	1	3289551907205	85	2102140	3	3289552102142	81	2376030	6	3289552376031	133
1909114		3289559091142		2102160	3	3289552102166	81	2376040	6	3289552376048	133
1909116		3289559091166		2102180	3	3289552102180	81	2376050	6	3289552376055	133
1909118		3289559091180		2103140	3	3289552103149		2376060	6	3289552376062	133
1909140	1	3289551909148	86	2103160	3	3289552103163		2376070	6	3289552376079	133
1909160	1	3289551909162	86	2104000	1	3289552104009	39	2376080	6	3289552376086	133
1909180	1	3289551909186	86	2105000	1	3289552105006	39	2377000	6	3289552377007	132
1913112	1	3289559131121	86	2110180	1	3289552110185	66	2377002	6	3289552377021	132
1913114		3289559131145		2110200	1	3289552110208	66	2377004	6	3289552377045	132
1913120	1	3289551913121	86	2110220	1	3289552110222	66	2377006	6	3289552377069	132
1913140	1	3289551913145	86	2110240	1	3289552110246	66	2377030	6	3289552377038	132
1916116	1	3289551799848	66	2111180	1	3289552111182	66	2378020	6	3289552378028	133
1916118	1	3289551799855	66	2111200	1	3289552111205	66	2378030	6	3289552378035	133
1917114	1	3289550121220	66	2112140	1	3289552112141	66	2378040	6	3289552378042	133
1917116	1	3289559171165	66	2112160	1	3289552112165	66	2378050	6	3289552378059	133
1987000	1	3289551987009	24	2112180	1	3289552112189	66	2378060	6	3289552378066	133
1993180	6	3289551993185	112	2113160		3289552113162		2378070	6	3289552378073	133
1993220	1	3289551993222	112	2120000	1	3289552120009	68, 78	2378080	6	3289552378080	133
1993250	6	3289551993253	112	2121000	1	3289552121006	68	2379000	6	3289552379001	132
2012500	6	3289552012007	124	2123000	1	3289552123000	68	2379002	6	3289552379025	132
2012502	6	3289552012021	124	2201000		replaced by 3201000		2379004	6	3289552379049	132
2012504	6	3289552012045	124	2268008	1	3289552268084	70	2379006	6	3289552379063	132
2012506	6	3289552012069	124	2268411	1	3289552268411	70	2379030	6	3289552379032	132
2012508	6	3289552012083	124	2268812	1	3289552268817	70	2380020	6	3289552380021	133
2012530	6	3289552012304	124	2269008	1	3289551699131	70	2380030	6	3289552380038	133
2020000		091511501261		2269411	1	3289551699148	70	2380040	6	3289552380045	133
2042028	1	3289552042004	48	2269812	1	3289551699155	70	2380050	6	3289552380052	133
2043028	1	3289552043001	48	2278000	1	3289552278007	79	2380060	6	3289552380069	133
2044038	1	3289552044381	48	2285200	1	3289552285203	86	2380070	6	3289552380076	133
2067812	1	3289551699353	68	2285215	1	3289551799787	86	2380080	6	3289552380083	133
2068008	1	3289551699360	68	2285227	1	3289551799794	86	2381000	6	3289552381004	132
2068411	1	3289551699377	68	2300500	6	3289552300500	124	2381002	6	3289552381028	132
2068812	1	3289551699384	68	2300502	6	3289552300029	124	2381004	6	3289552381042	132
2070008	1	3289551699469	70	2300504	6	3289552300043	124	2381006	6	3289552381066	132
2070411	1	3289552070410	70	2300506	6	3289552300067	124	2381030	6	3289552381035	132
2070812	1	3289552070816	70	2300530	6	3289552300302	124	2433000	1	3289552433000	38
2074008	1	3289552074081	70	2301504	6	3289552301040	124	2455180	1	3289550300342	80
2074411	1	3289552074111	70	2301506	6	3289552301064	124	2455200	1	3289550300359	80
2074812	1	3289552074128	70	2308020	6	3289552308209	133	2455220	1	3289550300434	80
2075008	1	3289552075002	70	2308030	6	3289552308308	133	2457160		3289550300465	
2078122	1	3289551799879	83	2308040	6	3289552308407	133	2457180		3289550300472	
2078124	1	3289551799886	83	2308050	6	3289552308506	133	2477813	1	3289551699612	68
2078126	1	3289551799893	83	2308060	6	3289552308605	133	2550110			
2078220		3289552078225		2308070	6	3289552308704	133	2589090	5	3289552589095	38, 55
2078240		3289552078249		2308080	6	3289552308803	133	2594010	5	3289552594107	38, 59
2078260		3289552078263		2313000	6	3289552313005	132	2597004	5	3289552597047	54
2094008	1	3289551699643	70	2313002	6	3289552313029	132	2597008	5	3289552597085	54
2094411	1	3289551699650	70	2313004	6	3289552313043	132	2597012	5	3289552597122	54
2094812	1	3289551699667	70	2313006	6	3289552313067	132	2597015	5	3289552597153	54
2096006	1	3289552096069	82	2313030	6	3289552313036	132	2599019	5	3289550259916	38, 59



NEW CODE

DELETED CODE

REPLACED BY

CODE		EAN Code	Page
2602002	5	3289552602024	56
2602003	5	3289552602031	56
2602004	5	3289552602048	56
2602005	5	3289552602055	56
2602006	5	3289552602062	56
2602007	5	3289552602079	56
2602008	5	3289552602086	56
2602010	5	3289552602109	56
2603002	5	3289552603021	54
2603004	5	3289552603045	54
2603006	5	3289552603069	54
2603008	5	3289552603083	54
2603010	5	3289552603106	54
2603012	5	3289552603120	54
2603015	5	3289552603151	54
2603310	5	3289552633103	54
2603312	5	3289552633127	54
2603315	5	3289552633158	54
2605010	5	3289552605100	62
2605012	5	3289552605124	62
2605014	5	3289552605148	62
2605016	5	3289552605162	62
2605018	5	3289552605186	62
2605020	5	3289552605209	62
2605022	5	3289552605223	62
2605024	5	3289552605247	62
2605030	5	3289552605308	62
2609000	5	3289552609009	55
2612000	5	3289552612009	
2613002	5	3289552613020	38, 54
2613004	5	3289552613044	38, 54
2613006	5	3289552613068	38, 54
2613008	5	3289552613082	38, 54
2613010	5	3289552613105	38, 54
2613012	5	3289552613129	38, 54
2613015	5	3289552613013	38, 54
2613025	5	3289552613259	38, 54
2615015	5	3289552615154	38, 55
2617000	5	3289552617004	55
2619000	1	3289552619008	120
2628000	1	3289550503408	
2631008	5	3289552631086	59
2632002	5	3289552632021	56
2632003	5	3289552632038	56
2632004	5	3289552632045	56
2632005	5	3289552632052	56
2632006	5	3289552632069	56
2632007	5	3289552632076	56
2632008	5	3289552632083	56
2632009	5	3289552632090	56
2632010	5	3289552632106	56
2634008	6	3289552634087	76
2634015	6	3289552634155	
2679110	6	3289552679354	93
2679150	6	3289552679354	93
2680010	1	3289552680107	116
2683000	1	3289552683009	43
2684000	15	3289552684006	116
2684008	15	3289552684082	116
2684014	15	3289552684143	116
2685000	12	3289552685003	116
2685014	12	3289552685140	116
2687000	1	3289552687007	43
2689010	5	3289552689100	116
2700040	1	3289552700409	118
2701025		3289552701253	
2717500	3	3289552717506	118
27185000	10	3289552718503	118
2731000	1	7340017900409	116

CODE		EAN Code	Page
2783010	5	3289552783105	38, 55
2783015	5	3289552783150	38, 55
2847120	10	3289552847128	135
2848120	10	3289552848125	135
2857180		3289552857189	
2860180		3289552398644	
2862180		3289552862183	
2866180	1	3289552866181	99
2866250	1	3289552866259	99
2868180		3289552398903	
2869180	1	3289552398973	105
2871000	6	3289552871000	131
2871002	6	3289552871024	131
2871004	6	3289552871048	131
2871030	6	3289552871307	131
2875050			
2875150			
2876180		3289550508830	
2877180	10	3289550508977	104
2879110			
2886504	6	3289552886042	124
2886506	6	3289552886066	124
2886508	6	3289552886080	124
2887004	6	3289552887049	128
2887006	6	3289552887063	128
2888000	6	3289550509004	124
2888030	6	3289550508991	124
2888502	6	3289552888022	124
2888504	6	3289552888046	124
2888506	6	3289552888060	124
2888508	6	3289552888084	124
2890006	6	3289552890063	127
2890008	6	3289552890087	127
2890010	6	3289552890100	127
2890012	6	3289552890124	127
2890014	6	3289552890148	127
2890016	6	3289552890162	127
2890018	6	3289552890186	127
2890020	6	3289552890209	127
2890022	6	3289552890223	127
2897500	6	3289552897000	132
2897502	6	3289552897024	132
2897504	6	3289552897048	132
2897506	6	3289552897062	132
2897508	6	3289550501862	132
2897530	6	3289552897536	132
2898500		3289552898007	
2898502		3289552898021	
2898504		3289552898045	
2898506		3289552898069	
2898530		3289552898304	
2940110	1	3289552940119	105
2942000	1	3289550505570	43
2943100	1	3289550505587	
2946000	1	3289552946999	41
2948000	1	3289552948993	41
2960550	6	3289552960254	108
2960580	10	3289552960582	108
2961580	10	3289552961589	108
2963550	6	3289552963552	108
2963580	10	3289552963583	108
2964550	6	3289552964559	108
2964580	10	3289552964580	108
2965180	10	3289550503491	108
2965250	6	3289552965259	108
2967180	6	3289550503453	112
2967250	6	3289550503460	112
2968580		3289552397142	

CODE		EAN Code	Page
2969580	1	3289552397159	98
2970550	1	3289552970253	98
2970580	1	3289552970185	98
2972580	1	3289552972189	101
2973580	1	3289552973186	105
2974580	1	3289552397135	
2976580	1	3289552976187	95
2981250	6	3289552981259	112
2981580	6	3289552981181	112
2987080	1	3289552987084	24
2987180	1	3289552987183	24
2987220	1	3289552987220	24
2987250	1	3289552987251	24
2988180	6	3289550506232	103
2991110			
2992029	6	3289550503675	113
2992040	6	3289550503682	113
2992055	6	3289550503699	113
2997040		replaced by 1770040	
2997080		replaced by 1770080	
2997180		replaced by 1770180	
2997220		replaced by 1770220	
2997250		replaced by 1770250	
2998180	6	3289552998189	113
3001000	1	3289553001000	47
3002000	1	3289553002007	47
3003000	12	3289553003004	43
3005000		3289553005008	
3007000	1	3289553007002	45
3014000	1	0072632835053	42
3015000	1	3289553015007	45
3053000	6	3289553053009	117
3054000	1	0072632835039	42
3055000	1	0072632835022	42
3066000	1	3289553066009	43
3073000	1	3289553073007	48
3073036	1	3289553073036	48
3073048	1	3289553073048	48
3098000	1	3289553098000	46
3099000	1	3289553099007	46
3101000	1	3289553101007	46
3103000	1	3289553103001	46
3110180	1	3289553110184	43
3110250	1	3289553110252	43
3111000	1	3289553111006	47
3113000	1	3289553113000	47
3131000	12	3289553131004	43
3133000	12	3289553133008	43
3173000	1	3289553173004	48
3174000	1	3289553174001	48
3191000	1	3289553191008	46
3201000	1	3289553201004	26
3214000	1	793579749714	42
3222006	5	3289553222061	60
3230000		3289553230004	
3252120	10	3289553252129	94
3252150	10	3289553252150	94
3253180	6	3289553253188	107
3253250	6	3289553253256	106
3254180		3289553254185	
3254250		3289553254253	
3255180	6	3289553255182	107
3266180	6	3289553266188	100
3266250	6	3289553266256	100
3267180	6	3289553267185	107
3267250	6	3289553267253	107
3314000	1	3289553314001	15, 25
3319001	1	3289553319013	120

CODE	📦	EAN Code	Page
3348000	1	3289553348006	115
3372000		replaced by 394000	
3401000		3289553401008	
3480000	1	3289550348009	24, 115
3482000	4	3289553482007	32, 40
3541050	1	3289553541056	26
3541100	1	3289553541100	26
3541200		3289553541209	
3684008	15	3289553684081	117
3684012	10	3289553684128	117
3685008	20	3289553685088	117
3685012	10	3289553685125	117
3693000	12	3289553693007	117
3740020	1	3289553740206	40
3740025	1	3289553740251	40
3740030	1	3289553740305	40
3741150	1	3289553741159	40
3742000	1	3289553742002	41
3743001	1	3289553743016	41
3743002	1	3289553743023	41
3743003	1	3289553743030	41
3745000	1	3289553745003	41
3746000	1	3289553746000	41
3758007	12	3289553758072	117
3808000		3289553541209	
3887180	10	3289553887185	108
3933110	10	3289553933110	103
3934110	10	3289553934117	97
3943100	5	3289553943102	
3946000	1	3289553946004	41
4111000	6	3289554111005	130
4111002	6	3289554111029	130
4111004	6	3289554111043	130
4111006	6	3289554111067	130
4111030	6	3289554111302	130
4112030	6	3289554112309	130
4112040	6	3289554112408	130
4112050	6	3289554112507	130
4112060	6	3289554112606	130
4113030	6	3289554113306	130
4113040	6	3289554113405	130
4114100	6	3289554114105	130
4114140	6	3289554114143	130
4120000	5	3289554120007	118
4121000	5	3289554121004	118
4541760	1	3289554541000	
4542030	1	3289554542038	50
4542048	1	3289554542489	50
4550050	1	3289550504566	95
4550510	1	3289554550002	95
4550550	1	3289554550552	95
4552110	1	3289550503651	101
4553510	1	3289554553515	97
4554110	1	3289554554116	104
4610050	1	3289554510051	94
4610150	1	3289554610157	94
4679007	1	3289554679079	93
4679510	1	3289554679000	93
4679550	1	3289554679550	93
4684110	1	3289554684110	96
4828110	1	3289550482819	101
4862050	1	3289554862051	94
4862110	1	3289554862112	94
4875005	1	3289550503507	92
4875510	1	3289554875518	92
4875550		3289554875556	
4877110	1	3289554877116	93
4878110	1	3289554878113	92

NEW CODE	DELETED CODE	REPLACED BY	
CODE	📦	EAN Code	Page
4879510	1	3289554879516	92
4889110	1	3289554889119	96
4920510	1	3289554920515	101
4923510	1	3289554923516	95
4927510	1	3289554927514	99
4932050	1	3289554932501	97
4932110	1	3289554932112	97
4932115	1	3289559321157	97
4933110	1	3289554933119	100
4935110	1	3289554935113	103
4936510	1	3289554936516	120
4937110	1	3289554937117	102
4940510	1	3289554940513	105
4940515	1	3289554940056	105
4941110	1	3289554941114	97
4942110	1	3289554942111	103
4943110	1	3289554943118	104
4944110	1	3289554944115	94
4945110	1	3289550018575	
4946110	1	3289550018568	
4947110	1	3289550018520	96
4991050	1	3289550503729	99
4991510	1	3289554991003	99
4991550	1	3289554991553	99
4994050	1	3289554994059	103
4994110	1	3289550507116	103
5315120	5	3289555315129	35
5315180	5	3289555315181	35
5316120	5	3289555316126	35
5392120	5	3289555392014	35
5392180	5	3289555392021	35
5396120	5	3289559613122	35
5396180	5	3289559613184	35
5396220	5	3289559613221	35
5398120	5	3289555398122	35
5399120	5	3289555399006	35
5541028	1	3289555541023	50
5542048	1	3289555542488	49
5801020		3289555801028	
5801030	6	3289555801035	127
5801040	6	3289555801042	127
5801050	6	3289555801059	127
5801060	6	3289555801066	127
5801070	6	3289555801073	127
5801080	6	3289555801080	127
5802020	120	3289555802209	125
5802030	120	3289555802308	125
5802040	120	3289555802407	125
5802050	60	3289555802506	125
5802060	60	3289555802605	125
5802070	60	3289555802704	125
5802080	30	3289555802803	125
5811030			
5811040			
5811050			
5811060			
5811070			
5814010			
5814012			
5814014			
5814016			
5814018			
5814020			
5816010	6	3289555816107	128
5816012	6	3289555816121	128
5816014	6	3289555816145	128
5816016	6	3289555816169	128
5816018	6	3289555816183	128

CODE	📦	EAN Code	Page
5816020	6	3289555816206	128
5824008	6	3289555824089	127
5824010	6	3289555824102	127
5824012	6	3289555824126	127
5824014	6	3289555824140	127
5824016	6	3289555824164	127
5824018	6	3289555824188	127
5824020	6	3289555824201	127
5825008	6	3289555825086	127
5825010	6	3289555825109	127
5825012	6	3289555825123	127
5825014	6	3289555825147	127
5825016	6	3289555825062	127
5825018	6	3289555825185	127
5825020	6	3289555825208	127
5987080		replaced by 1770080 + 987080	
5987180		replaced by 1770180 + 987180	
5987220		replaced by 1770220 + 987220	
5987250		replaced by 1770250 + 987250	
6050030	1	3289556050302	74
6050065	1	3289556050654	74
6053004	5	3289556053044	71
6053006	1	3289556053006	71
6053008	1	3289556053082	71
6053010	1	3289556053013	71
6056504	0	3289556056540	49, 71
6056506	0	3289556056007	49, 71
6056508	0	3289556056083	49, 71
6056510	2	3289556056519	49, 71
6080030	5	3289556080309	74
6080065	5	3289556080651	74
6083004	5		71
6083006	5	3289556083065	71
6083008	5	3289556083089	71
6083010	5	3289556083102	71
6086504	5		71
6086506	5	3289556086509	71
6086508	5	3289556086585	71
6086510	5	3289556086516	71
6972180		3289552398927	
6974180		3289552398965	
6987040		replaced by 1770040 + 7987040	
7291025	6	3289552913304	131
7291035	6	3289552913403	131
7541035	2	3289557541359	49
7541060	1	3289557541069	49
7550110	10	3289557550115	95
7553110	10	3289557553116	97
7647110	10	3289557647112	96
7679110	10	3289557679113	93
7684110		3289557684117	
7828110	10	3289550782810	101
7862110	10	3289557862119	94
7875070	10	3289557870350	92
7875110	10	3289557875119	92
7878110	1	3289557878110	92
7879110	1	3289557879117	92
7879150	1	3289557879353	92
7889110	1	3289557889116	96
7920110	10	3289557920116	101
7932110	10	3289557932119	97
7933110	10	3289557933116	100
7935110	10	3289557935110	103

**NEW CODE****DELETED CODE****REPLACED BY**

CODE		EAN Code	Page
7937110	10	3289557937114	102
7947025	6	3289559473252	126
7947030	6	3289559473306	126
7947035	6	3289559473351	126
7947040	6	3289559473405	126
7947045	6	3289557947458	126
7947060	6	3289557947601	126
7987040	5	3289557987041	24
7991110	10	3289557991116	99
7994110	10	3289557994117	103
46111835	1	3289554611864	84
46118035	1	3289551907700	84
60510012	1		74
60510018	1		74
60510030	1		74
60510050	1		74
60511012	1		74
60511018	1		74
60511030	1		74
60511050	1		74
60513012	1		74
60513018	1		74
60513030	1		74
60513050	1		74
60810012	5		74
60810018	5		74
60810030	5		74
60810050	5		74
60811012	5		74
60811018	5		74
60811030	5		74
60811050	5		74
60813012	5		74
60813018	5		74
60813030	5		74
60813050	5		74
62700035	1	3289554615749	84
62710035	1	3289554615756	84
80507099		replaced by 80624	
80656193			53
99200535	6	3289559920053	113
99201535	6	3289559920152	113
190211835	1	3289554615862	85
190311835	1	3289554615879	85
190410035	1	3289554615763	85
190611835	1	3289554615886	84
190618035	1	3289554615770	84
190711235	1	3289554615893	85
190711435	1	3289554615015	85
190711635	1	3289554615022	85
190711835	1	3289554615039	85
190911435	1	3289554615046	86
190911635	1	3289554615152	86
190911835	1	3289554615114	86
193550019	10	3289551930241	95
193550029	10	3289551930210	95
193879029	10	3289551930258	92
193991019	10	3289551930326	99
193991029	10	3289551930296	99
3568018193	6	3289553568183	53
3568024193	6	3289553568244	53
3568040193	6	3289553568404	53
3570024193	6	3289553570025	53
3570030193	6	3289553570322	53
3570040193	6	3289553570421	53
3570060193	6	3289553570605	53
481002N	5	3289554819024	58
481003N	5	3289554819031	58

CODE		EAN Code	Page
481004N	5	3289554819048	58
481005N	5	3289554819055	58
481006N	5	3289554819062	58
481007N	5	3289554819079	58
481008N	5	3289554819086	58
481010N	5	3289554819109	58
481012N	5	3289554811295	58

NOTES



A large area of the page is filled with horizontal dotted lines, providing a template for handwritten notes.

SUSTAINABLE, RESPONSIBLE COMMITMENT

- > **We combat MSDs** with innovative products that meet today's requirements
- > Our partners have **industrial expertise** and a **local approach**
- > **90% of our purchases** are made in Europe
- > **Use of the expertise and European network** of our partners

We are committed to being a **responsible company** that respects people and the environment

We are family business that **safeguards local employment in the long term** and ensures **respect for the well-being** of men and women.

L'Outil Parfait is dedicated to a management system that makes it possible to be **actively involved in sustainable development**.

Our commitment to young craftsmen is a key factor in maintaining a relationship of trust, which is a major issue for us on a daily basis.

This relationship is **based on support for training**.

We give priority to short circuits. Our supplies comply with the various standards and the sustainable forest management system.

We prefer to source sustainable materials.

Our packaging is intelligent, and without excess.

We ensure that we comply with the environmental requirements.

L'OUTIL PARFAIT®

MANUFACTURER SINCE 1920



EXPORT CATALOGUE 2026

L'OUTIL PARFAIT
Marquardt S.A.S - Capital 1 500 000€
Z.I. de Racine - BP 8 - 63650 LA MONNERIE
FRANCE

Tél. +33 (0)4 73 51 40 27
E-mail : export@outilparfait.com

outilparfait.com



Encre végétale
Paper made from 40% recycled material

CODE D2026E



3 1340532 026992